

PRK-1UM



SR

UREĐAJ ZA RAZVOJ KONCENTRACIJA VEČNOG ŽIVOTA PRK-1UM MODIFIKOVANI TRI-MOD

Opis i metode rada sa uređajem

Uređaj za razvoj koncentracija večnog života PRK-1UM modifikovani tri-mod

Opis i metode rada sa uređajem

Sadržaj

• Napomena pre korišćenja uređaja PRK-1UM	3
• Instrukcije za uključivanje uređaja PRK-1UM	4
• Rad uređaja PRK-1UM u režimu SD kartice	12
• Opis uređaja za razvoj koncentracija večnog života PRK-1UM modifikovanog tri-mod	13
• Podaci o sertifikatima, patentima i žigovima	15
• Podaci o operabilnosti uređaja PRK-1U	16
• Rezultati primene uređaja za razvoj koncentracija večnog života PRK-1U	17
• Metodike rada sa uređajima za razvoj koncentracija večnog života PRK-1U	17
• Obrazloženje cene ugovora o podlicenci za PO sa PRK-1UM	19
• Obrazac Ugovora o nalogu za pravo da se organizuju ugovori o podlicenci za PO sa PRK-1UM	21
• Fotokopije patenta „Način sprečavanja katastrofa i uređaj za njegovo ostvarivanje“ i patenta „Sistem prenosa informacije“	24
• Patent „Uređaj razvoja koncentracija večnog života PRK-1U trorežimski“	26
• Sertifikati o registraciji industrijskog dizajna uređaja PRK-1UM	47
• U Velikoj Britaniji (Zavod za intelektualnu svojinu)	47
• U Belgiji, Holandiji, Luksemburgu (Beneluks (BOIP))	51
• U Švajcarskoj (Švajcarski savezni institut za intelektualnu svojinu)	52
• U Nemačkoj (Deutsches Patent- und Markenamt)	55
• Fotokopije žigova	60
• Sertifikat „Idivorski Laboratorija“ o usaglašenosti uređaja PRK-1UM sa propisima elektromagnetske kompatibilnosti	69
• Dodatni izveštaj „Idivorski laboratorija“ o ispitivanjima uređaja PRK-1UM sa laserom klase 1	71

Na osnovu i u skladu sa patentom Grigorija Grabovoja „Način sprečavanja katastrofa i uređaj za njegovo ostvarivanje” i drugim njegovim izumima gde se vrši normalizacija upravljačkog impulsa koji generiše čovek u vidu elementa svoje svesti, u vidu sijanja misli, Grigorij Grabovoj je stvorio uređaj za razvoj koncentracija večnog života PRK-1UM tri-mod.

U tom uređaju je založen princip sličnosti sa ljudskim organizmom. On se sastoji u tome što sam uređaj ima dva prekidača ali pri tome rade tri režima. Analogija se sastoji u tome što se u ljudskom organizmu misli rađaju i realizuju razne ali se pri tome masa tela ne uvećava. Uređaj ima funkcije veštačke inteligencije.

- Prvi režim je univerzalni.
 - Drugi režim je pojačavanje stacionarne faze realnosti.
 - Treći režim je pojačavanje dinamičke faze realnosti (impulsno-periodični).
- Impulsno-periodični režim se uključuje samom šemom uređaja bez prekidača.

Dodatno se može uključivati laser i može se uključiti OLED ekran u režimima očitavanja brojčanih nizova. Jedan iz lasera je stalno uključen, a drugi funkcioniše zajedno sa senzorom pokreta koji je instaliran na gornjoj površini uređaja. Ako nema korisnika, drugi laser se isključuje.

Klikom na dugme otvara se datoteka. Na ekranu se pojavljuju brojevi snimljeni na SD kartici.

Napomena pre korišćenja uređaja PRK-1UM

Pre korišćenja uređaja za razvoj koncentracija večnog života PRK-1UM modifikovanog tri-mod, upoznajte se sa načinom korišćenja ovog uređaja, opis uređaja je na linku: <https://pr.grigori-grabovoi.world/index.php/technical-devices/prk-1um>
Opis možete naći na ukazanom linku na raznim jezicima.

Sigurnost i eksploatacija:

Obratite se preko linka <https://pr.grigori-grabovoi.world/index.php/technical-devices/prk-1um>

UPOZORENJE:

Kako bi se izbegao kratak spoj i posledice toga, uključujući i mogućnost požara elementa uređaja na mestu kratkog spoja, ne izlagati uređaj vlažnosti. Uređaj ne sme da padne sa velike visine.

Standardi:

Informacija o standardima, sertifikatima, znacima usaglašenosti, patentnoj zaštiti, tovarnim markama, koje se odnose na uređaj za razvoj koncentracija večnog života PRK-1UM tri-mod, mogu se naći na samom uređaju, u dokumentaciji priloženoj uz uređaj u kutiji i na zvaničnom web sajtu <https://pr.grigori-grabovoi.world>

Republika Srbija i Evropska unija. Informacija o reciklaži:

Znak precrtanog kontejnera za otpad na uređaju, u dokumentaciji uređaja označava da se uređaj mora odvojeno odlagati od kućnog otpada u skladu sa lokalnim zakonima i propisima.

Napomene o laseru:

Ovaj uređaj je u skladu sa bezbednosnim normativima i u skladu sa normativima spada u uređaje sa laserom klase 1 ($\lambda = 650\text{nm}$. $P_o \leq 0,4 \text{ mW}$.).

Laseri klase 1 su vrlo male snage, sa nivoom zračenja koji nije u stanju da stvara opasnost za ljudsko oko.

Uređaj PRK-1UM nije izvor direktnog laserskog zračenja, jer je laserski snop ograničen kućištem.

Na uređaju je standardna oznaka, kao i informacije o bezbednosti laserskog zračenja klase 1.



Adapter napajanja odgovara propisima:

“O sigurnosti niskonaponske opreme” и “Elektromagnetna kompatibilnost tehničke opreme”

Individualni podaci uređaja:

Broj modela i individualni serijski broj uređaja nalaze se na poleđini uređaja. Koristite te brojeve u slučaju da se obraćate proizvođaču, čija su adresa i web sajt dati na poleđini uređaja.

Korišćeni materijali i testiranja:

Uređaj je napravljen od materijala koji nisu štetni za organizam, koriste se materijali koji se koriste u lemljenju, koji ne sadrže olovo ili ostale štetne materije.

Svaka komponenta svakog detalja uređaja pažljivo se procenjuje kao predmet ekološki bezopasan.

Svaki uređaj se pre eksploatacije testira neprekidnim dvadesetčetvoročasovnim radom u svakoj od tri faze rada uređaja što garantuje normalne karakteristike daljeg rada uređaja.

Instrukcije za uključivanje uređaja PRK-1UM

Postavite uređaj na horizontalnu površinu.

Priključite na električnu mrežu napona od 220 (110) volti



ili spojite na prenosivi Power bank punjač.



Uređaj radi u tri režima.
Uređaj je u isključenom stanju kada su sva dugmad uređaja u položaju „dole”.

Slika 1: Uređaj je u isključenom stanju.



Slika 1.

Prvi režim se uključuje pritiskom na dugme 1 prema gore. Ovo dugme treba da zasija.

Slika 2: Uključen je prvi režim. Dugme (2 i 3) je u položaju „dole”.



Slika 2.

Drugi režim se uključuje pritiskom na dugme 2 prema gore. Ovo dugme mora da zasija.

Slika 3: Uključivanje drugog režima. Proizvodi se iz prvog režima. Dugme (2) u položaj „gore”.



Slika 3.

Drugi režim se ispoljava statičnim emitovanjem svetlosti sa leve strane uređaja, unutar uređaja. Kontrolise se sijanjem prozirnog LED-a sa leve strane (slika 4).



Slika 4.

Treći režim se uključuje isključivanjem i uključivanjem dugmeta 1 kada dugme 2 ostaje u uključenom stanju (gornjem položaju). Dugmad 1 i 2 moraju sijati. Treći režim se ispoljava impulsno - periodičnim emitovanjem svetlosti sa leve strane uređaja, unutar uređaja.

Slika 5: Uključen je treći režim. Dugme (2) je u položaju „gore”.



Slika 5.

Da bi se odredilo u kom režimu uređaj radi u datom trenutku, dovoljno je pogledati dugme za menjanje režima (2).

Ako dugme (2) ne sija, znači da uređaj radi u prvom režimu (Slika 2).

Ako dugme (2) sija, uređaj radi u drugom režimu (Slika 3). Ako dugme (2) treperi, uređaj radi u trećem režimu. Takođe u trećem režimu treperi LED sa leve strane uređaja.

Slika 6. Uključivanje dugmeta (3).



Slika 6.

Dugme (3) aktivira dodatne funkcije uređaja. Dugme (3) se može uključivati samo u prvom režimu i u drugom režimu rada uređaja. Pri tome se uključuju dva lasera (slika 7) i OLED displej ili LED dioda sa desne strane prednjeg panela.

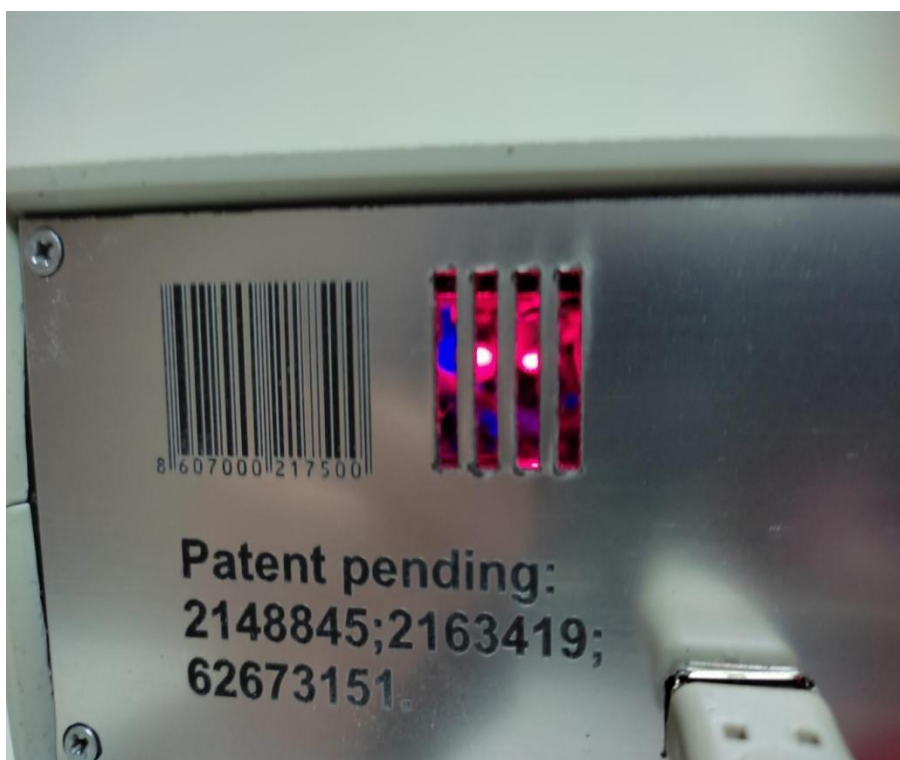

Slika 7.

Jedan od lasera sija konstantno, a drugi funkcioniše zajedno sa senzorom pokreta koji je instaliran na gornjoj površini uređaja. Ako nema korisnika, drugi laser se isključuje (slika 8).

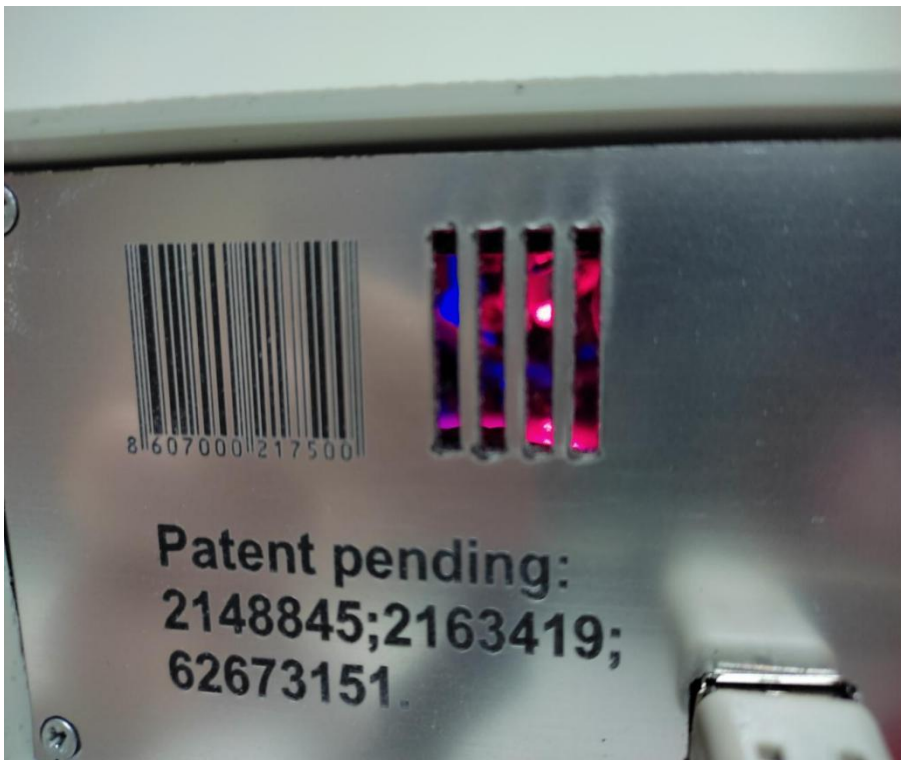

Slika 8.

I uključuje se kada se korisnik pojavi na udaljenosti manjoj od 3 metra od uređaja. Dodatno se mogu koristiti brojčani nizovi. U tu svrhu se potrebni brojčani niz snima na SD karticu. Kartica se postavlja u poseban slot na prednjem panelu sa desne strane (slika 9).



Slika 9.

Za čitanje brojčanih nizova sa SD kartice može se koristiti OLED displej ili se može osaznavati prikaz brojčanih nizova sa SD kartice u impulsno-periodičnom radu LED-a. U prvom slučaju, neophodno je isključiti dugme (3), ubaciti karticu i uključiti dugme (3). Na displeju se pojavljuju natpisi (slika 10), ili LED dioda počinje da treperi (slika 11).



Slika 10.



Slika 11.

Da bi se promenila funkcija ekrana ili LED-a, neophodno je pritisnuti veliko dugme desno od ekrana.

Za čitanje informacija na ekranu pritiskom na gornje dugme, koje se nalazi levo od displeja, pomeramo kursor nadole na naziv fajla 1.TXT (slika 12).



Slika 12.

Pritiskom na donje dugme otvaramo fajl. Na ekranu se pojavljuju brojevi snimljeni na SD kartici (slika 13).



Slika 13.

Za uključivanje režima za čitanje brojčanih nizova pomoću LED-a, neophodno je pritisnuti veliko dugme desno od ekrana. LED, koji se nalazi na prednjem panelu uređaja sa desne strane, počinje da pulsira frekvencijom i intenzitetom koji odgovara očitanoj cifri (slika 14).



Slika 14.

Za isključivanje uređaja neophodno je isključiti dugmad (1), (2) i (3).

Rad uređaja PRK-1UM u režimu SD kartice

1) Prvo uključivanje uređaja u režimu SD kartice.

Prilikom prvog uključivanja režima rada SD kartice, sadržaj SD kartice se prikazuje na ekranu.

Nakon što korisnik učita brojčani niz sa SD kartice na ekran izborom datoteke '1.txt', na ekranu se prikazuje učitani brojčani niz. Zatim pritiskom na dugme sa desne strane ekrana, LED sa desne strane počinje da treperi.

2) Uključivanje uređaja drugi i naredni put u režimu SD kartice.

Kada prilikom ponovnog uključivanja uređaja u režimu SD kartice, brojčani niz se automatski očitava sa SD kartice i LED desno počinje da treperi i na ekranu se prikazuje tekst "Init SD... OPEN".

Ako LED sa desne strane treperi, to znači da je uređaj automatski pročitao SD karticu (i datoteku „1.txt“) i da radi u normalnom režimu.

3) Kako ponovo prikazati sadržaj SD kartice na ekranu:

Potrebno je da ISKLJUČITE režim SD kartice (dugme 3), zatim treba da pritisnete dugme sa desne strane ekrana i ponovo UKLJUČITE režim SD kartice (dugme 3).

Nakon toga, sadržaj SD kartice će biti prikazan na ekranu. Zatim, da biste prikazali brojčani niz na ekranu, potrebno je da uradite korake opisane u instrukcijama (odeljak o izboru datoteke „1.txt“), a zatim pritisnite dugme sa desne strane ekrana da LED treperi.

Opis uređaja za razvoj koncentracija večnog života PRK-1UM modifikovanog tri-mod

Razvoj koncentracija koje obezbeđuju večni život svima sprovodi se posredstvom usmerenja pažnje na prijemnik generisanog biosignala i kontrole rezultata koncentracije. U psihologiji je poznato da što se više sprovodi koncentracija, utoliko se brže dostiže cilj, optimizuju se događaji.

U uređaju, preklapanjem polja, od generisanja biosignala, elektromagnetnih polja, uz taj psihološki faktor, po zakonu dejstva sveopštih veza, dodaje se upravljanje za cilj koncentracije. Uređaj razvija koncentracije stvaralačkog upravljanja.

U teoriji talasne sinteze poznato da misao generisano u zračenje može imati istovremeno dva kvantna stanja. Jedno od tih stanja se nalazi na senzornom elementu predajnika signala, a drugo na prijemniku signala. To omogućava stvaranje uređaja za realizaciju večnog života koji uzajamno deluju sa mišljenjem. U patentima za pronalazke Grigorija Grabovoja zapisano je da čovek-operator generiše informaciju u vidu zračenja misli. Za rad uređaja PRK-1UM čovek koncentriše zračenje, koje se stvara pri misli, na sočivima koja se nalaze na gornjoj površini uređaja. Misao sadrži cilj koncentracije.

Dejstvo koncentracije za sadašnje i buduće vreme sprovodi se na senzornom elementu predajnika signala koji se sastoji od sočiva. Vrš se kružna kretanja koncentracija od sočiva manjeg prečnika u smeru suprotnom od kretanja kazaljke na satu preko sočiva većeg prečnika.

Kod koncentracija koje se odnose na prošle događaje kružno kretanje misli koncentracije vršilo se u smeru kretanja kazaljke na satu, od sočiva manjeg prečnika ka sočivu većeg prečnika. I zrak koncentracije pri tome nije bio odzgo kao u slučaju koncentracija za sadašnje i buduće događaje, već sa strane unutrašnje optičke jedinice uređaja.

U skladu sa sistemom prenosa informacije opisanim u patentu, drugo kvantno stanje misli se procesira na prijemniku signala koji se nalazi u obliku optičkog uređaja unutar uređaja. Realizacija načina normiranja prilikom koncentracije izložene u patentu „Način sprečavanja katastrofa i uređaj za njegovu realizaciju” vrši se preklapanjem polja od generisanja biosignala, elektromagnetnih polja. Uz psihološki faktor po zakonu dejstva sveopštih veza dodaje se upravljanje za cilj koncentracije.

Uređaj univerzalno radi na razvoju sledećih koncentracija za realizaciju večnog života:

Upravljanje 1:

Razvoj koncentracija večnog života za bilo koji događaj.

Upravljanje 2:

Razvoj koncentracija večnog života za upravljačko jasnoviđenje.

Upravljanje 3:

Razvoj koncentracija večnog života za upravljačko prognoziranje.

Upravljanje 4:

Razvoj koncentracija večnog života za podmlađivanje.

Razvijajući koncentracije večnog života uz pomoć uređaja, potrebno je ostvarive tehnologije osvajati duhovnim razvojem ili upravljačkim jasnoviđenjem. Kako biste umeli da radite isto to, uključujući procese zaštite i normalizacije zdravlja putem koncentracija svoje svesti.

U modifikovanom uređaju PRK-1UM u skladu sa teorijom sinteze talasa, koju je stvorio Grigorij Grabovoj, funkcijama PRK-1U dodate su sledeće nove funkcije:

1. Povećana je snaga funkcije samostalnog rada bez koncentracije. Mala ili kratkotrajna koncentracija se pojačava mnogo više nego kod PRK-1U. Dugotrajna koncentracija se višestruko pojačava raznim progresijama.

2. Dinamika materije radi u statičnoj sredini kroz SD karticu i LED. Statični talas realnosti u obliku volumetrijske fizičke materije i električna struja kao dinamični talas realnosti izlaze na svetlosni impuls sa disperzijom svetlosti u spoljašnje, tj. beskonačno večno okruženje.

3. Unutar uređaja radi bezbedni, konstantno dejstvujući laser kao statični talas realnosti, sa svojstvima lasera u oblastima visokog intenziteta emitovanja unutar laserskog zraka sa disperzijom kroz sočivo u beskonačnost, u večno okruženje. Funkcija dinamičnog talasa realnosti radi od drugog lasera unutar uređaja, koji se aktivira senzorom pokreta.

4. Putem SD kartice pomoću softvera ploče Arduino NANO ostvaruje se prelazak materije u beskonačno večno okruženje kroz broj na displeju ili LED-u.

Svaki režim rada uređaja u vezi sa radom veštačke inteligencije pojačava se SD karticom. Koristeći brojeve na SD kartici mogu se vršiti koncentracije sa potrebnim upravljanjem na neophodnom nivou. Na SD karticu se mogu povremeno dodavati brojčani nizovi. Brojčani niz koji je snimljen na SD kartici prilikom fabričkog sastavljanja uređaja se ne briše. Ovom brojčanom nizu Podlicenzenti na svojim računarima mogu dodavati na SD karticu individualne brojčane nizove, brojčane nizove iz autorskih dela Grigorija Grabovoja. Time se obezbeđuje razvoj koncentracija večnog života za sebe i sve u odabranim oblastima.

5. Na gornjoj površini kućišta uređaja nalazi se kompas sa oznakom za lokaciju igle kompasa paralelno sa zracima lasera koji se nalaze unutar uređaja. Preporučuje se da se početna pozicija korišćenja uređaja PRK-1UM započinje kada je igla kompasa usmerena na oznaku. Zatim se može birati individualna pozicija igle kompasa.

SD kartica, u skladu sa procesom sinteze talasa, ostvaruje prelazak elektrona u beskonačnu sredinu kroz broj na displeju. Treći režim, u vezi sa radom veštačke inteligencije, može zahtevati korišćenje nizova SD kartice. Pošto pri zaustavljanju trećeg režima koncentracija na brojevima SD kartice omogućava simuliranje rada trećeg režima. Poređenje rada trećeg režima i simulirane verzije omogućava ubrzano razvijanje koncentracija večnog života. Na taj način se mogu brže realizovati ciljevi upravljanja ubrzano razvijajući i jačajući koncentracije mentalnih modela događaja.

Novi modifikovani uređaj PRK-1UM ima smanjene dimenzije 20-16-6,5 cm pogodne za mobilnu upotrebu i može se napajati kako iz električne mreže tako i sa prenosivog Power bank punjača.

Modifikovani uređaj PRK-1UM se u detaljima razlikuje od PRK-1U prisustvom sledećih detalja koji obezbeđuju dodatne funkcije PRK-1UM:

1. Ploče Arduino Nano V3, minikontroler ATmega168 -16 MHz, čip CH340G (2 kom.), koji su softverski i hardverski alati za izgradnju sistema u oblasti elektronike i robotike. Softverski deo se sastoji od shell programa (IDE) za pisanje programa, njihovo kompajliranje i programiranje hardvera. Hardverski deo je set montiranih štampanih ploča. Programski jezik Arduino je C++ sa Wiring framework-om.

Autor realizovanog programa je Grigorij Petrovič Grabovoj.

2. SD adapter.

3. OLED ekran za prikaz broječnih nizova sa SD kartice u tekstualnom obliku.

4. LED za prikaz broječnih nizova sa SD kartice u obliku svetlosnih impulsa.

5. Laseri (2 kom.)

6. Senzor pokreta.

7. Kompas.

8. Mikro dugmad (2 kom.)

9. Dugme-prekidač Br. 3

10. Dugme za promenu pozicije.

11. USB konektor za povezivanje eksternog napajanja na uređaj.

12. Kabal za napajanje koji se priključuje preko USB konektora.

Pronalazač uređaja PRK-1UM je:

Grigorij Petrovich Grabovoi

Proizvođač uređaja je:

Individualni preduzetnik "GRIGORII GRABOVOI PR KONSALTING TECHNOLOGIES OF ETERNAL DEVELOPMENT" koji obavlja svoju delatnost na osnovu Rešenja o državnoj registraciji fizičkog lica Grigorij Petrovich Grabovoi kao Individualnog preduzetnika Br.63983276 izdatog 21.09.2015. godine od strane Agencije za privredne registre Republike Srbije.

Podaci o sertifikatima, patentima i žigovima

Uređaj za razvoj koncentracija večnog života PRK-1UM tri-mod je prošao kroz ispitivanja elektromagnetske kompatibilnosti u državnoj laboratoriji „Idivorski Laboratorije“ (<http://www.idvorsky.com>), državne ustanove Institut „Mihajlo Pupin“ (IMP) (<http://www.pupin.rs/en/home/>), koji je u nadležnosti Ministarstva nauke Srbije.

Ispitivanja uređaja za razvoj koncentracija večnog života PRK-1UM tri-mod na elektromagnetsku kompatibilnost sprovedena u Idivorski Laboratorijama su u punoj saglasnosti sa Direktivom o elektromagnetskoj kompatibilnosti Evropske unije. Zato dobijeni sertifikat o normalnim parametrima uređaja PRK-1UM koji su izdali Idivorski laboratorije po Direktivama Evropske unije u saglasnosti sa međunarodnim pravom omogućava postavljanje AAA, CE znakova usaglašenosti na uređaj.

Idivorski laboratorije su ovlašćeni od Ministarstva privrede Republike Srbije da izdaju takve sertifikate za prodaju uređajâ sa karakteristikama koje su u okvirima direktiva Evropske Unije, zato u Evropskoj uniji nema ograničenja za korišćenje uređajâ PRK-1UM.

Izveštaj od Idvorski laboratorija na engleskom jeziku o ispitivanjima uređaja za razvoj koncentracija večnog života PRK-1UM tri-mod, sa zaključkom o tome da su karakteristike ovog uređaja u saglasnosti sa standardima Evropske unije nalazi se na sajtu označenom na poleđini uređaja, na stranici:

Glavni izveštaj „Idvorski laboratorija” o ispitivanjima uređaja PRK-1UM: https://pr.grigori-grabovoi.world/images/PRK1UM/EMC_Test_Report_Idvorski_Lab_PRK-1UM_en.pdf;

Drugi izveštaj „Idvorski laboratorija” o ispitivanjima uređaja PRK-1UM sa laserom klase 1: https://pr.grigori-grabovoi.world/images/PRK1UM/EMC_Test_Report_Idvorski_Lab_part_new_laser_PRK-1UM_en.pdf

Uređaj za razvoj koncentracija večnog života PRK-1UM tri-mod je prošao kompleksna ispitivanja sigurnosti u Laboratoriji ANL. U izveštaju se nalazi oznaka CE, koja se odnosi na ceo uređaj zajedno sa uređajima za električno napajanje.

Izveštaj Laboratorije ANL na engleskom jeziku o ispitivanjima uređaja za razvoj koncentracija večnog života PRK-1UM tri-mod sa zaključkom o tome, da su karakteristike ovog uređaja u saglasnosti sa standardima Evropske unije, nalazi se na sajtu onaznačenom na poleđini uređaja, na stranici:

https://pr.grigori-grabovoi.world/images/PRK1UM/Test_Report_AN_LAB_CO_PRK-1UM_en.pdf

Sertifikati koji su dobijeni na osnovu datih izveštaja dati su na stranici sajta:

<https://pr.grigori-grabovoi.world/index.php/technical-devices/prk-1um>

Podaci o izumima, u saglasnosti sa kojima je izrađen uređaj, dati su na natpisu na uređaju sa brojevima patentne zaštite: «Manufactured under invention patents: US 12,144,599 B2; 2148845; 2163419.».

Uređaj se proizvodi pod registrovanim zaštitnim znacima GRABOVOI® i GRIGORI GRABOVOI®.

Podaci o operabilnosti uređaja PRK-1U

Po pitanju operabilnosti uređaja za razvoj koncentracija PRK-1U saopštava se da je operabilnost ovog uređaja za razvoj koncentracija večnog života objektivno utvrđena sledećim:

1. Fizičko-matematičkom teorijom, matematičkim proračunima, rezultatima eksperimenata, potvrđenim mnogobrojnim sastavom doktorâ fizičko-matematičkih i tehničkih nauka, koji ulaze u sastav uredničkog kolegijuma časopisa „Elektronska tehnika” i objavljenim u tom časopisu: <https://licenzija8.wordpress.com/science/>

2. Patentima za izume Grigorija Grabovoja: <https://licenzija8.wordpress.com/patents/>

3. Video-protokolima ispitivanja uređaja sa dobrim sistemnim rezultatima koja su sprovedi bez izuzetka svi koji su upisani na ispitivanja, 128 učesnika ispitivanjâ: <https://pr.grigori-grabovoi.world/index.php/technical-devices/video-testimonials>

4. Potpisanim protokolima uspešnih ispitivanja uređaja: <https://pr.grigori-grabovoi.world/index.php/technical-devices/written-testimonials>

5. Periodom od preko osam godina sa stotinama testiranja i rada uređaja bez negativnih rezultata, sa mnogobrojnim pozitivnim rezultatima <https://grigori-grabovoi.tech/prk1u-results-sr>

Rezultati primene uređaja za razvoj koncentracija večnog života PRK-1U

Kratki zbornik rezultata primene uređaja za razvoj koncentracija večnog života PRK-1U. Deo 1 i deo 2 se mogu preuzeti na linku:

<https://pr.grigori-grabovoi.world/index.php/technical-devices/testimonies-prk-1u>
<http://educenter.grigori-grabovoi.world/course/index.php?categoryid=30>

Rezultati primene uređaja prevedeni na razne jezike mogu se pročitati na linku <https://grigori-grabovoi.tech/prk1u-results-sr>

Metodike rada sa uređajima za razvoj koncentracija večnog života PRK-1U

Metode primene se sastoje u tome, što se u intervalu vremena od 1 do 3 minuta, a po potrebi i više, sprovodi koncentracija po cilju upravljanja 1, 2, 3, 4, bez uključenog uređaja i sa uključenim uređajem. Rezultati se upoređuju s tačke gledišta efekta razvoja koncentracija koje obezbeđuju večni život. Taj efekat se primenjuje za razvoj koncentracija po navedenim upravljanjima putem višekratne primene uređaja.

1. Razvoj koncentracija večnog života za podmlađivanje

1.1. Možete se koncentrisati na podmlađivanju sebe, zatim možete na podmlađivanju drugih. Ako smatrate da ste mladi i još uvek ne treba da se podmlađujete, tada treba da sprovedite koncentracije kao trening, kako biste u budućnosti, kada poželite da se podmlađujete, vi to već umeli da radite.

Metoda:

1.1. U datoj koncentraciji možete da predstavite željeni uzrast i za vreme koncentracija da ga osetite do nivoa realnog opažanja sebe u tom uzrastu.

1.2. U ovoj koncentraciji čak i mladi ljudi treba da se koncentrišu, zato što je to potrebno za ubuduće, da bi čovek mogao u bilo kom momentu da se podmladi. Odnosno, tome treba da se učimo u mladosti. U ovoj koncentraciji treba da usredsredite pažnju na kičmu. I kod kičme zamislite brojeve 498. Na taj način od sijanja tih brojeva se treba podmlađivati. To jest, svetlost od brojeva ide na kičmu i kroz kičmu se treba podmlađivati u potpunosti.

1.3. Iz prostora između sočiva izlazi materija večnog života koju generiše uređaj. Ona ide iz prostora između sočiva. Potrebno je da se MVŽ izvede na repnu kost kičme, kako bi MVŽ

pošla navise do mozga i istovremeno drugi deo materije iz malog sočiva treba kroz desno i levo oko da se spoji sa materijom iz repne kosti, kako bi bio zatvoren krug.

1.4. Potrebno je uraditi izvođenje materije večnog života iz sredine između sočiva, izvodi se direktno u mozak. Odatle u kičmenu moždinu (udova). I kroz nju u organizam na sve ćelije.

2. Razvoj koncentracija večnog života za bilo koji događaj

2.1 Prvo se treba koncentrisati na lokalnom odeljku materije svog organizma, na primer radi normiranja.

Zatim možete takvu koncentraciju da sprovedete za druge.

Dalje se možete koncentrisati na bilo kom događaju.

2.2 U toj koncentraciji treba preneti kao nekakav elemenat svesti u beskonačnu budućnost i iz te beskonačne budućnosti videti, da ti događaji, koje ste odredili, oni su se realizovali. Na primer, kako vi gledate na prošlost i tamo su se realizovali vama potrebni događaji, to je isto - vi iz budućnosti gledate na prošlost, koja, iz budućnosti sadašnjost jeste prošlost. Ili budućnost, koja je dalje, takođe predstavlja - jedan elemenat budući, drugi za sledeći budući - je prošli. Saglasno, dobija se, da treba pogledati kao unazad. I iz beskonačne budućnosti pogledati unazad i videti, da su se realizovali događaji koje ste vi odredili.

3. Razvoj koncentracija večnog života za upravljačko jasnoviđenje

Prvo treba primeniti upravljačko jasnoviđenje, razmotrivši u sadašnjem vremenu prostor iz koga ste izašli, ili u kome ste se nalazili nekoliko sati ranije.

Zatim možete primeniti upravljačko jasnoviđenje u odnosu na bilo koji događaj, poželjno je da stavite cilj upravljanja koji vam je zaista potreban u realizaciji.

Preporuke:

Za vreme pregleda događaja primenom koncentracije upravljačkog jasnoviđenja istovremeno se mogu korigovati događaji ako je potrebno. Pošto se upravljačko jasnoviđenje razlikuje od običnog jasnoviđenja time, što se primenom upravljačkog jasnoviđenja istovremeno sa pregledom događaja ostvaruje, ako je potrebno korigovanje događaja za obezbeđivanje večnog života.

4. Razvoj koncentracija večnog života za upravljačko prognoziranje

Pri upravljanju za upravljačko prognoziranje stavljate takođe cilj upravljanja – razviti uz pomoć uređaja svest i duh toliko, kako bi u perspektivi bilo moguće da postupate bez uređaja, primenjujući samo razvijene duh i svest.

Metoda:

U ovoj koncentraciji treba da razmotrite svoju beskonačnu budućnost, večnu budućnost, i da vidite u toj večnoj budućnosti, na primer, tako za milion godina, uopšte, u bilo kojoj tački beskonačne budućnosti da vidite konkretno nekakve svoje događaje. Šta konkretno vi radite tamo. I pri tome, treba da dijagnostikujete iz sadašnjeg vremena svoj ćelijski sastav, tj. ćelije organizma, funkcije organizma. Dijagnostikujete da je to sve normalno u toj beskonačnoj budućnosti. Bolje je stvoriti odmah normu u sadašnjem vremenu.

Druge metodike rada sa PRK-1U su postavljene na Internet na stranici <http://educenter.grigori-grabovoi.world/course/index.php?categoryid=29>

Obrazloženje cene ugovora o podlicenci za PO sa PRK-1UM

Prema podlicencnom ugovoru za predmet intelektualne svojine saopštava se: u pruženu na korišćenje intelektualnu svojinu spadaju:

- Svi materijali Programa Obuke na raznim jezicima na fleš memoriji;
- Montaža uređaja PRK-1UM sa individualnim optičkim podacima;
- Ustupanje prava na korišćenje PRK-1UM na 4 godine i duže na postojećem resursu ili uz ažuriranje nakon 4 godine prema dodatnom sporazumu;
- Ustupanje prava na korišćenje korisničkog naloga sa duplicirajućim i pojačavačkim uređajem PRK-1UM na 4 godine;
- Ustupanje na 4 godine pristupa Biblioteci Obrazovnog Centra koja sadrži sve materijale Programa Obuke i u koju se stalno unose svi novi materijali G.P. Grabovoja.

Cena materijalâ unetih na fleš memoriju po ceni po kojoj se oni nekoliko godina uspešno prodaju na Amazonu, u internet prodavnicama www.ggrig.com, www.grigori-grabovoi.center, (tj. realna tržišna vrednost materijalâ Programa Obuke) iznosi 10280 evra (informacija je od 2016. godine, sada je cena materijala veća).

Izveštaji o prodaji sa Amazona

https://drive.google.com/file/d/1w2kNgyq_Ep0hxoGfm28fPrbz_WkrfDMu/view

Pristup Biblioteci Obrazovnog Centra na 4 godine procenjuje se uporednom cenom. Pošto godišnja pretplata za Biblioteku Obrazovnog Centra (informacija je na sajtu site www.grigori-grabovoi.world) iznosi 2500 evra, onda suma pretplate na 4 godine saglasno tome iznosi 10000 evra.

Fakture za uplatu pristupa biblioteci i izvod iz banke da su fakture plaćene

<https://drive.google.com/file/d/1f0llsb0-zA578i8TRqAHv5j3no3dx653/view>

Montaža uređaja PRK-1UM sa individualnim optičkim podacima, ustupanje prava na korišćenje PRK-1UM na 4 godine i duže, a takođe i ustupanje prava na korišćenje korisničkog naloga sa duplicirajućim i pojačavačkim uređajem PRK-1UM na 4 godine uključuju uporedive troškove. Ti troškovi uključuju cenu koštanja rada na fizičko-matematičkom računu, na programiranju, cenu koštanja sastavnih delova, cenu koštanja isporuke, montaže i drugih radova. Ukupno se dobija uporediva cena.

Na taj način za cenu ugovora se pruža paket sa vrednošću mnogo puta većom, uzimajući u obzir takođe stalna obnavljanja Biblioteke Obrazovnog Centra i mogućnost dodavanja modifikacija uređaja.

U skladu sa stručnim pristupom proceni intelektualne svojine B.B. Leontjeva, utvrđuje se sledeće:

Svaki predmet intelektualne svojine treba razumeti kao samostalan i integrisan u biznis sistem znanjâ. Svaki predmet intelektualne svojine sjedinjuje u sebi svojstva koja omogućavaju da se on izdvaja, ne samo po vrsti i kategoriji, na primer, intelektualna svojina, patent, know-how, regulisan članovima Građanskog zakonika prenos tehnolgoija, već takođe i da se on identifikuje sa pozicije pravne pripadnosti i sa uzimanjem u obzir ukupnih dobiti koje se od njega dobijaju. Bilo koji kvalitativni rezultat intelektualne delatnosti u sferi društvenih odnosa postaje predmet intelektualne svojine, koji ima, minimum, tri grupe kriterijuma: tehničke (ili umetničke), pravne i ekonomske.

Prvobitno se predmet intelektualne svojine karakteriše tehničkim kvalitativnim sadržajem, koji omogućava njegovu procenu s tačke gledišta funkcionalnog korišćenja. To su osnovna tehnička svojstva: funkcionalna primenljivost, trošenje, resurs. Primenljivost svih dela Grigorija Petroviča Grabovoja je dokazana rezultatima radova koji su protokolarno oformljeni i izloženi u knjigama u tri toma „Praksa upravljanja. Put spasenja”. Trošenja delâ Grigorija Petroviča Grabovoja s tačke gledišta njihovog ponovnog čitanja nema, jer postoje mnogobrojna svedočanstva da se pri ponovnom i višekratnom čitanju delâ Grigorija Petroviča Grabovoja dublje usvajaju tehnologije izložene u delima, i više od toga, na novi način se razume materijal. To se dešava u vezi sa ideologijom i praksom obezbeđivanja večnog života svima koje su založene u tekstove delâ Grigorija Petroviča Grabovoja, pri kojima delo donosi rezultat obezbeđivanja večnog života bez ograničenja u vremenu. Time je takođe dokazano da delâ Grigorija Petroviča Grabovoja imaju beskonačni resurs.

Primenljivost uređaja za razvoj koncentracija PRK-1UM je utvrđena sledećim:

1. Podacima koji se nalaze u odeljku „Podaci o operabilnosti uređaja” u ovoj brošuri.
2. Trošenje uređaja za razvoj koncentracija PRK-1UM u vezi sa korišćenim materijalima je neznatan.
3. Resurs uređaja za razvoj koncentracija PRK-1UM je neograničen vremenski, jer uređaj razvija koncentracije bazirajući se na sadašnjem nivou razvoja koncentracija za vreme primenjivanja uređaja.
4. Dalje, predmet intelektualne svojine se karakteriše prostorno-vremenskim kriterijumima u sferi prava i ekonomije. Ekonomsko-pravni odnosi su ovde u uzajamnoj zavisnosti i razmatrati ih odvojeno je neprikladno.

U sferi prava prostornu karakteristiku predstavlja teritorija delovanja, vremensku - rok delovanja, koji određuju parametre civilnog prometa datog predmeta prava. Osnovnu pravnu karakteristiku predmeta svojine predstavlja kvalitet pravne zaštite, iz koje proističe potencijal kvalitativne zaštite. Što je kvalitetnije obezbeđena pravna zaštita, utoliko efektivnija može biti zaštita od nesavesnih korisnika tog predmeta svojine. Zaštita se zalaže u etapi stvaranja predmeta i pojačava se u etapi njegovog korišćenja. Ipak, najprivlačniji predmeti svojine se neretko moraju štiti od nasrtajâ već u etapi stvaranja, ali najčešće pak, u etapi korišćenja. Prostorno-vremenski režim obezbeđenosti i zaštite je utoliko aktuelnije, što je kvalitetniji sadržaj samog predmeta svojine, to jest, što je efektivniji njegov tehnički sadržaj, koji je uvek primaran. Zato visokokvalifikovani inženjeri i naučnici moraju da rade u kontaktu sa visokokvalifikovanim specijalistima za patente, zastupnicima i pravnicima za patente, da bi visokom tehničkom kvalitetu odgovarao visok pravni kvalitet zaštite, koji se dodeljuje datom predmetu. Pravna podrška predmetu svojine, izražena režimima obezbeđenosti i zaštite predmeta, oličava u njemu ideju pravičnosti.

Kao što pokazuju činjenice, Grigorij Petrovič Grabovoj je uzimao u obzir izložene podatke štiteći svoju intelektualnu svojinu.

Dela Grigorija Petroviča Grabovoja su zaštićena registracijom u različitim strukturama za registraciju autorskog prava, uključujući Kancelariju za registraciju Autorskih prava Kongresne biblioteke SAD-a: TX 7-324-403 od 06.02.2008. godine, TXu 1-607-600 od 08.02.2008. godine, TX 7-049-203 od 12.02.2008. godine, TX 6-975-628 od 13.02.2008. godine (podaci na zvaničnom veb-sajtu na Internet mreži su dati u vidu: TX0006975628/2008-02-13), TXu 1- 789-751 od 25.07.2011. godine. Adresa zvaničnog veb-sajta, Kancelarije za Autorska prava Kongresne biblioteke SAD-a, koja sadrži registracione podatke: www.cocatalog.log.gov. Adresa Kancelarije za Autorska prava Kongresne biblioteke

Obrazac Ugovora o nalogu za pravo da se organizuju ugovori o podlicenci za PO sa PRK-1UM

UGOVOR O NALOGU broj _____ Beograd « _____ » _____ 20____.	AGREEMENT OF AGENCY № _____ Belgrade « _____ » _____ 20____.
Individualni preduzetnik «Grigorii Grabovoi PR KONSALTING TECHNOLOGIES OF ETERNAL DEVELOPMENT», koji obavlja svoju delatnot na osnovu potvrde o državnoj registraciji fizičkog lica Grigorii Grabovoi kao individualnog preduzetnika od 21. septembra 2015. godine broj 63983276 izdatog od strane Agencije za priredne registre Republike Srbije, u daljem tekstu «Davalac naloga», sa jedne strane, i _____ _____ u daljem tekstu «Primalac naloga», sa druge strane, zajedno u daljem tekstu Strane, zaključili su ovaj građansko-pravni ugovor kako sledi:	Individual Entrepreneur “Grigorii Grabovoi PR KONSALTING TECHNOLOGIES OF ETERNAL DEVELOPMENT”, acting on the basis of the certificate of state registration of individual Grigorii Grabovoi as an individual entrepreneur of September 21, 2015 No. 63983276, issued by Business Registration Agency of the Republic of Serbia, hereinafter referred to as the “Principal” on the one hand, and _____ _____ hereinafter referred to as the “Attorney”, on the other hand, collectively referred to as Parties, have concluded this civil Agreement as follows:
1. PREDMET UGOVORA	1. THE SUBJECT OF THE AGREEMENT
1.1. Davalac naloga daje nalog, a Primalac naloga se obavezuje da u ime Davaoca naloga izvrši sledeće:	1.1. The Principal entrusts and the attorney undertakes to perform on behalf of the Principal the following:
1.1.1. Da organizuje plasman i potpisivanje ugovora o sublicenci za korišćenje Obrazovnog Programa po Učenju Grigorija Grabovoja sa uređajem za razvoj koncentracija PRK-1UM.	1.1.1. Organize promotion and signing of the sublicense Agreement for the use of the Education Program on the Teachings of Grigori Grabovoi with Device of Development of Concentrations PRK-1UM.
1.1.2. Da vrši prevođenje, sprovodi testiranje PRK-1UM, obavlja konsultacije sa Korisnikom podlicence do ispunjenja uslova ugovora, da organizuje isplate.	1.1.2. Provide translation, testing of PRK-1UM, consult the Sub-Licensee until fulfillment of the conditions of the Agreement and arrange payments.
1.1.3. Da pronalazi fizička i pravna lica – potencijalne Korisnike podlicence preko Internet resursa i na druge načine.	1.1.3. Carry out searches for individuals and legal entities - potential Sub-Licensees through Internet resources and in other ways.
1.1.4. Da organizuje potpisivanje sa Davaocem naloga ugovora o podlicenci za korišćenje dela Grigorija Grabovoja za održavanje seminara po njima, njihovog izdavanja, za korišćenje njegovih robnih znakova GRABOVOI® i GRIGORI GRABOVOI®.	1.1.4. Organize the signing of sublicense agreements with the Principal on the use of the works of Grigori Grabovoi for conduction of seminars, publishing, and on the use of his trademarks GRABOVOI® and GRIGORI GRABOVOI®.
1.2. Da redovno i ažurno predaje izveštaje Davaocu naloga o svome tekućem radu i o rezultatima toga rada. Da za realizaciju ugovora o podlicenci snosi solidarnu odgovornost sa Davaocem naloga, koji nastupa kao Davalac podlicence, proporcionalnu isplata Primaocu naloga.	1.2. Carry out regular and timely reporting to the Principal on the current activities and the results of these activities. Be held responsible, pro rata to the payments to the Attorney, for the implementation of the sublicense agreements jointly with the Principal acting as a Licensee.
2. PRAVA I OBAVEZE STRANA	2. RIGHTS AND OBLIGATIONS OF THE PARTIES
2.1. Davalac naloga zadržava pravo da sklapa ugovore o	2.1. The Principal reserves the right to enter into an agency

nalogu sa trećim licima.	contract with a third party.
2.2. Primalac naloga ima pravo da realizuje nalog koji mu je dat po ovom ugovoru na teritoriji zemalja Evropske Unije: Belgije, Federativne Republike Nemačke, Italije, Luksemburga, Holandije, Francuske, Velike Britanije, Danske, Irske, Grčke, Portugala, Španije, Austrije, Finske, Švedske, Mađarske, Kipra, Letonije, Latvije, Malte, Poljske, Slovačke, Slovenije, Češke, Estonije, Bugarske, Rumunije, Hrvatske, kao i Srbije, SAD, Južne Amerike, Indije, Japana, Kine i Australije.	2.2. The Attorney has the right to perform the assignment, given to him under this agreement, on the territory of the European Union: Belgium, the Federal Republic of Germany, Italy, Luxembourg, the Netherlands, France, Great Britain, Denmark, Ireland, Greece, Portugal, Spain, Austria, Finland, Sweden, Cyprus, Latvia, Lithuania, Malta, Poland, Slovakia, Slovenia, the Czech Republic, Estonia, Bulgaria, Romania and Croatia, as well as Serbia, the USA, South America, India, Japan, China and Australia.
2.3. Davalac naloga je obavezan da ako je to potrebno izda Primaocu naloga ovlašćenje za obavljanje radnji predviđenih tačkom 1.1 ovog ugovora.	2.3. The Principal is obliged to issue, if necessary, the power of attorney for the Attorney to carry out the actions provided for in paragraph 1.1 of this Agreement.
3. CENA USLUGA I NAČIN ISPLATE	3. COST OF SERVICES AND PAYMENT
3.1. Naknada Primaoca naloga iznosi 10% , porez i doprinosi uključeni, prihoda Davaoca naloga od svih ugovora o podlicenci, realizovanih preko Primaoca naloga. Isplata naknade vrši se posle ispunjenja uslova ugovora o podlicenci.	3.1. The Remuneration of the Attorney is 10% , all taxes included, of the income of the Principal, taxes included, for all carried out by the Attorney sublicense agreements. The payment of the remuneration is carried out in the case of fulfillment of the conditions of the sublicense agreement.
4. ROK VAŽENJA UGOVORA I NAČIN NJEGOVOG RASKIDA	4. TERM OF THE AGREEMENT AND ORDER OF ITS CANCELLATION
4.1. Ovaj Ugovor stupa na snagu od momenta njegovog zaključivanja i važi tri godine.	4.1. This Agreement shall enter into force upon its conclusion for the term of three years.
4.2. Ovaj ugovor može biti prevremeno raskinut prema zajedničkom sporazumu Strana, na zahtev jedne od Strana, ukoliko druga Strana suštinski prekrši ovaj ugovor i u drugim slučajevima, predviđenim važećim zakonima.	4.2. This Agreement may be prematurely terminated by mutual agreement of the Parties; at the request of one of the Parties; in case of material breach of this Agreement by the other Party; in other cases, stipulated by the current legislation.
5. ODGOVORNOST STRANA	5. RESPONSIBILITIES OF THE PARTIES
5.1. Pitanja nastala tumačenjem i primenom ovog ugovora koja nisu regulisana ovim ugovorom regulišu se na osnovu važećih zakona.	5.1. Issues arising from the interpretation and application of this Agreement that are not regulated by the Agreement shall be regulated on the basis of existing legislation.
5.2. Prilikom promene podataka, sedišta, bankarskih rekvizita svaka od strana je obavezna da drugu stranu o tome obavesti.	5.2. In case of the data, location, bank details changes, each Party is obliged to report it.
5.3. Bilo kakve izmene ili dopune uz ovaj ugovor smatraju se važećim ako su sačinjene u pismenoj formi i ako su ih potpisali ovlašćeni predstavnici Strana.	5.3. Any changes or additions to this agreement shall be valid if made in writing and signed by the authorized representatives of the Parties.
5.4. Uslovi ovog ugovora i dopunskih sporazuma uz njega predstavljaju poslovnu tajnu.	5.4. The terms of this Agreement and additional agreements are confidential.
5.5. Posle potpisivanja ugovora sva prepiska i svi pregovori i sporazumi gube svoju pravnu snagu, ako u ovom ugovoru nema pozivanja na njih.	5.5. After signing of the Agreement all correspondence and all negotiations and agreements lose their validity if they are not referred to in this Agreement.
5.6. Ugovor je sačinjen u dva primerka od kojih svaki ima jednaku pravnu snagu. Jedan primerak se nalazi kod Davaoca naloga, a drugi kod Primaoca naloga.	5.6. The Agreement is made in two copies, each having equal legal force, one of which Shall be kept by the Principal, the second one by the Attorney.
6. ADRESE, REKVIZITI I POTPISI STRANA	6. ADDRESSES, DETAILS AND SIGNATURES OF THE PARTIES
Davalac naloga:	The Principal:
Individualni preduzetnik Grigorii Grabovoi PR KONSALTING TECHNOLOGIES OF ETERNAL DEVELOPMENT	Individual Entrepreneur Grigorii Grabovoi PR KONSALTING TECHNOLOGIES OF ETERNAL DEVELOPMENT
Adresa:	Address:
11102, Ulica Kneza Mihaila 21A, lok.113, Beograd, Srbija	11102, Ulica Kneza Mihaila 21A, lok.113, Belgrade, Serbia
E-mail: grigorii.grabovoi.pr@gmail.com	E-mail: grigorii.grabovoi.pr@gmail.com
Skype:	Skype:
Rekviziti banke:	Bank details:
_____	_____

_____	_____
_____	_____
The Attorney:	The Attorney:
_____	_____
_____	_____
Adresa:	Address:
_____	_____
_____	_____
E-mail:	E-mail:
Skype:	Skype:
Pasoš:	Passport:
_____	_____
_____	_____
Rekviziti banke:	Bank details:
_____	_____
_____	_____
_____	_____
POTPISI STRANA:	SIGNATURES OF THE PARTIES:
Davalac naloga:	The Principal:
_____ /Grigorii Grabovoi/	_____ /Grigorii Grabovoi/
Primalac naloga:	The Attorney:
_____ / _____ /	_____ / _____ /

Uređaj PRK-1UM i povezani sa njime danonoćni individualni korisnički nalog mogu koristiti za testiranje i primenjivanje uređaja tokom 90 minuta osobe koje nisu na spisku Podlicenzenata. Ali pri tome treba 3 dana pre testiranja saopštavati o učesnicima na e-mail: grigorii.grabovoi.pr@gmail.com. (pošaljite kopiju pisma na e-mail grigorii.grabovoi.pr2@gmail.com).

Neophodno je dostavljati puno ime, prezime (i patronim) učesnika, datum rođenja i datum sprovođenja testiranja.

Finansijski uslovi dugotrajnog testiranja se mogu saznati slanjem zahteva na e-mail adresu: grigorii.grabovoi.pr@gmail.com. Testiranja do 8 minuta se mogu sprovoditi bez plaćanja. Testiranja i primenjivanja uređaja koja se plaćaju i koja su besplatna se mogu sprovoditi za ciljeve pružanja korišćenja uređaja drugim ljudima, promovisanja i zaključivanja ugovora o podlicenci za korišćenje Programa Obuke sa PRK-1UM.

Fotokopije patenta „Način sprečavanja katastrofa i uređaj za njegovo ostvarivanje“ i patenta „Sistem prenosa informacije“





Detaljna informacija o patentima sa opisom postavljena je na veb-sajtu
<https://licenzija8.wordpress.com/patents/>

Patent „Uređaj razvoja koncentracija večnog života PRK-1U trorežimski“



United States of America

To Promote the Progress of Science and Useful Arts

The Director

of the United States Patent and Trademark Office has received an application for a patent for a new and useful invention. The title and description of the invention are enclosed. The requirements of law have been complied with, and it has been determined that a patent on the invention shall be granted under the law.

Therefore, this United States

Patent

grants to the person(s) having title to this patent the right to exclude others from making, using, offering for sale, or selling the invention throughout the United States of America or importing the invention into the United States of America, and if the invention is a process, of the right to exclude others from using, offering for sale or selling throughout the United States of America, products made by that process, for the term set forth in 35 U.S.C. 154(a)(2) or (c)(1), subject to the payment of maintenance fees as provided by 35 U.S.C. 41(b). See the Maintenance Fee Notice on the inside of the cover.

Katherine Kelly Vidal

DIRECTOR OF THE UNITED STATES PATENT AND TRADEMARK OFFICE

Maintenance Fee Notice

If the application for this patent was filed on or after December 12, 1980, maintenance fees are due three years and six months, seven years and six months, and eleven years and six months after the date of this grant, or within a grace period of six months thereafter upon payment of a surcharge as provided by law. The amount, number and timing of the maintenance fees required may be changed by law or regulation. Unless payment of the applicable maintenance fee is received in the United States Patent and Trademark Office on or before the date the fee is due or within a grace period of six months thereafter, the patent will expire as of the end of such grace period.

Patent Term Notice

If the application for this patent was filed on or after June 8, 1995, the term of this patent begins on the date on which this patent issues and ends twenty years from the filing date of the application or, if the application contains a specific reference to an earlier filed application or applications under 35 U.S.C. 120, 121, 365(c), or 386(c), twenty years from the filing date of the earliest such application (“the twenty-year term”), subject to the payment of maintenance fees as provided by 35 U.S.C. 41(b), and any extension as provided by 35 U.S.C. 154(b) or 156 or any disclaimer under 35 U.S.C. 253.

If this application was filed prior to June 8, 1995, the term of this patent begins on the date on which this patent issues and ends on the later of seventeen years from the date of the grant of this patent or the twenty-year term set forth above for patents resulting from applications filed on or after June 8, 1995, subject to the payment of maintenance fees as provided by 35 U.S.C. 41(b) and any extension as provided by 35 U.S.C. 156 or any disclaimer under 35 U.S.C. 253.



US012144599B2

(12) **United States Patent**
Grabovoi

(10) **Patent No.:** **US 12,144,599 B2**
(45) **Date of Patent:** **Nov. 19, 2024**

(54) **DEVICE OF DEVELOPMENT OF CONCENTRATIONS OF ETERNAL LIFE PRK-1U IS OF THREE-MODES**

(71) Applicant: **Grigorii Petrovich Grabovoi**, Belgrade (RS)

(72) Inventor: **Grigorii Petrovich Grabovoi**, Belgrade (RS)

(*) Notice: Subject to any disclaimer, the term of this patent is extended or adjusted under 35 U.S.C. 154(b) by 718 days.

(21) Appl. No.: **16/504,293**

(22) Filed: **Jul. 7, 2019**

(65) **Prior Publication Data**
US 2020/0008700 A1 Jan. 9, 2020

Related U.S. Application Data

(60) Provisional application No. 62/695,756, filed on Jul. 9, 2018.

(51) **Int. Cl.**
A61B 5/05 (2021.01)
A61B 5/00 (2006.01)
A61M 21/00 (2006.01)
G09B 19/00 (2006.01)

(52) **U.S. Cl.**
CPC **A61B 5/05** (2013.01); **A61B 5/0059** (2013.01); **G09B 19/00** (2013.01); **A61M 21/00** (2013.01)

(58) **Field of Classification Search**
CPC ... A61B 5/05-055; A61B 5/168; A61B 5/486; A61B 5/4064; A61B 5/4854; A61B 5/242; A61M 21/00-02; A61M 2205/3303-3306; A61M 2205/583; A61M 2230/00

See application file for complete search history.

Primary Examiner — Thaddeus B Cox

(74) *Attorney, Agent, or Firm* — Georgiy L. Khayet

(57) **ABSTRACT**

Devices and methods for development of concentration are described herein. A three-mode device for development of concentration may include an optical sensing unit. The optical sensing unit may include a plurality of sensitive elements configured to sense a signal provided by a user. The signal may be associated with a plurality of electromagnetic fields. The plurality of sensitive elements may be configured to impose the plurality of electromagnetic fields onto each other to obtain an outgoing signal. The device may further include an optical emitting unit configured to emit the outgoing signal and one or more lenses for focusing concentration of the user. The one or more lenses may be associated with the optical sensing unit. The device may further include two switches for switching between a plurality of operation modes and a lighting unit to indicate each of the plurality of operation modes by emitting a predetermined light signal.

15 Claims, 10 Drawing Sheets

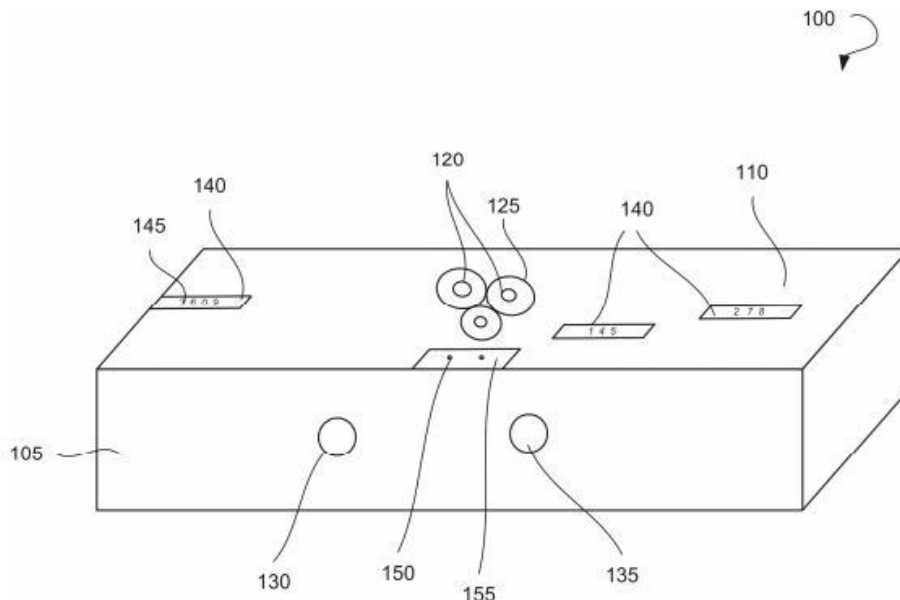

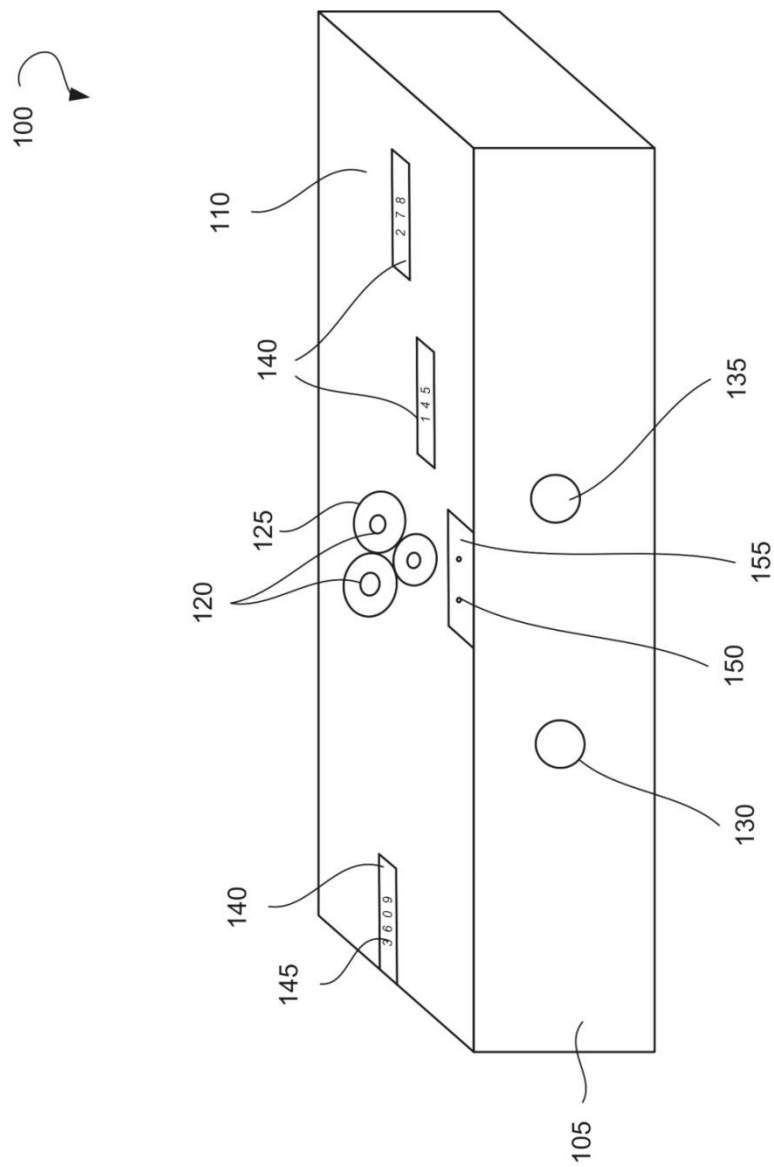

FIG. 1

200

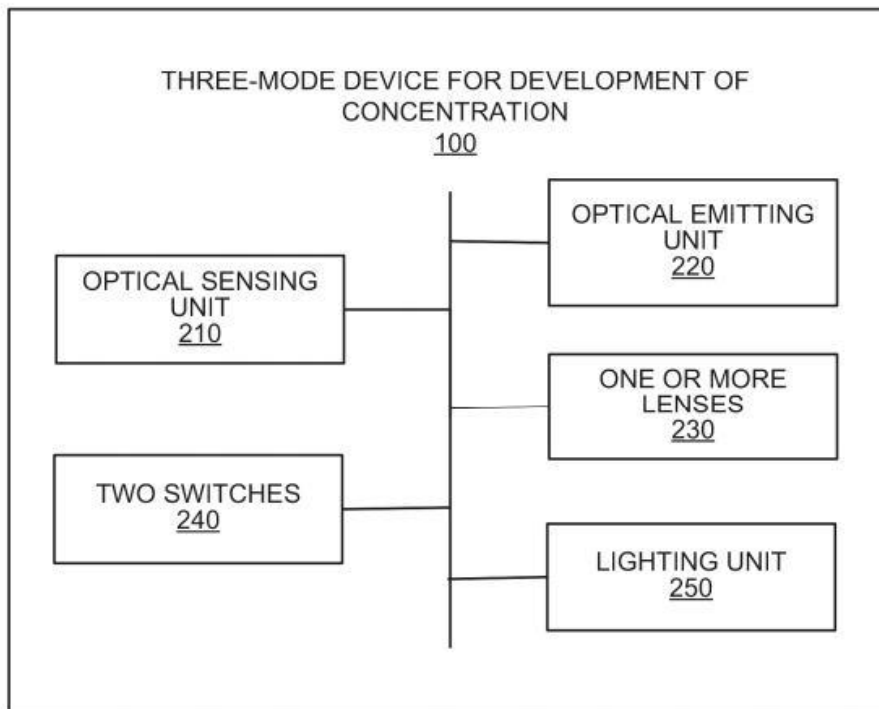

FIG. 2

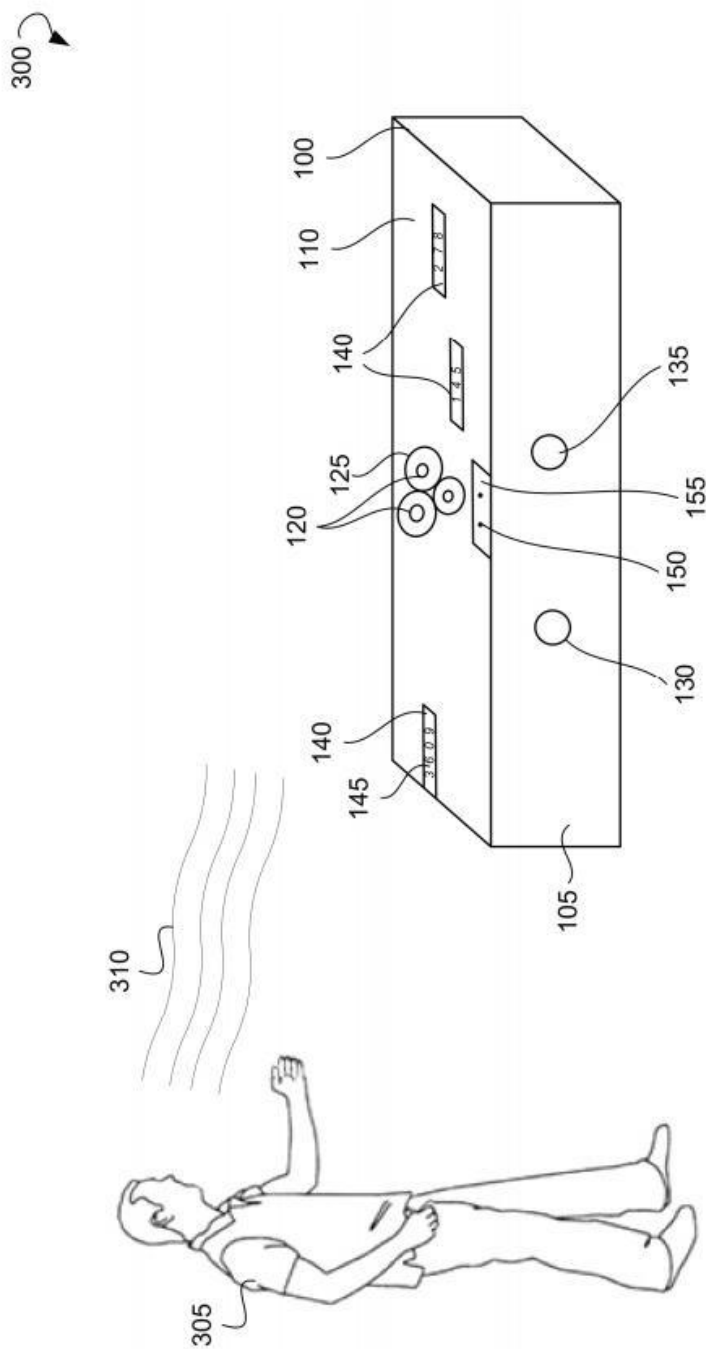

FIG. 3

400

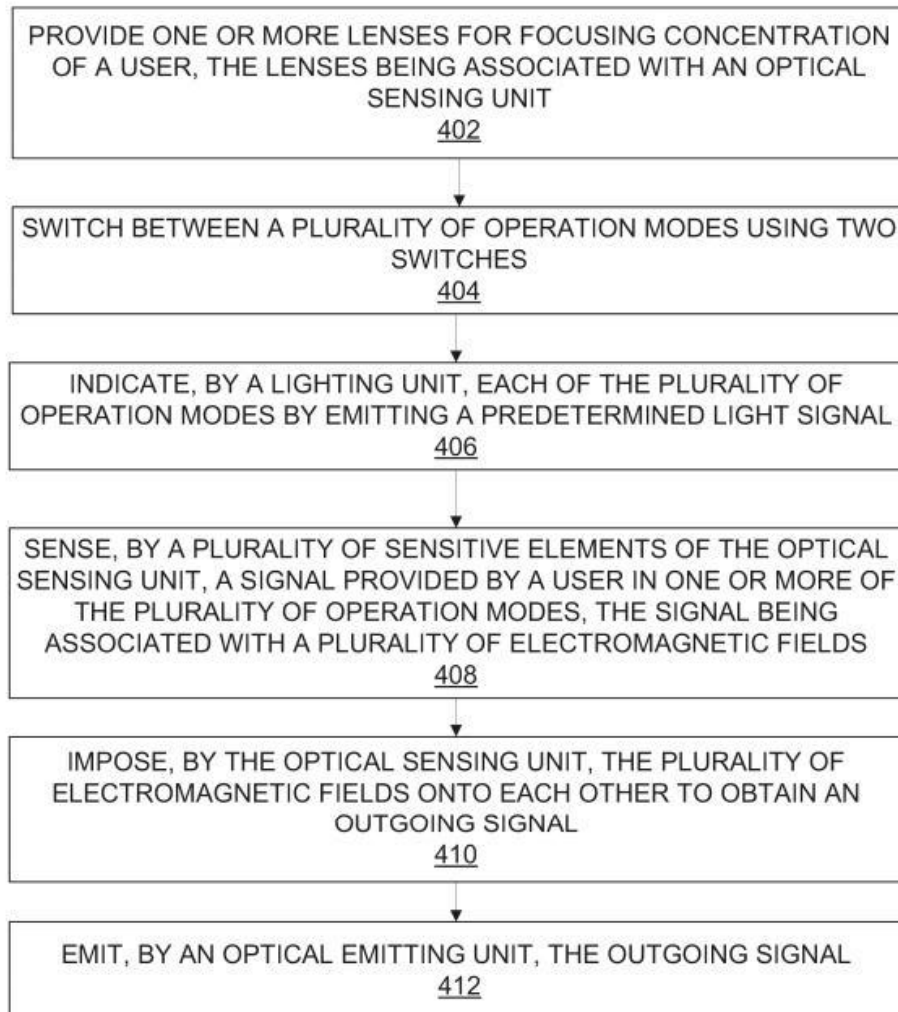
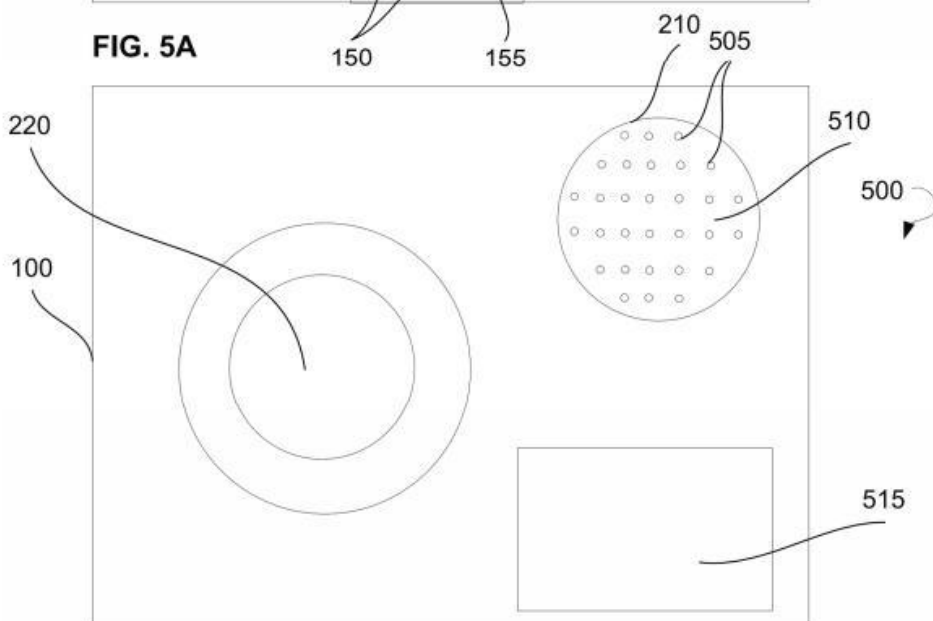
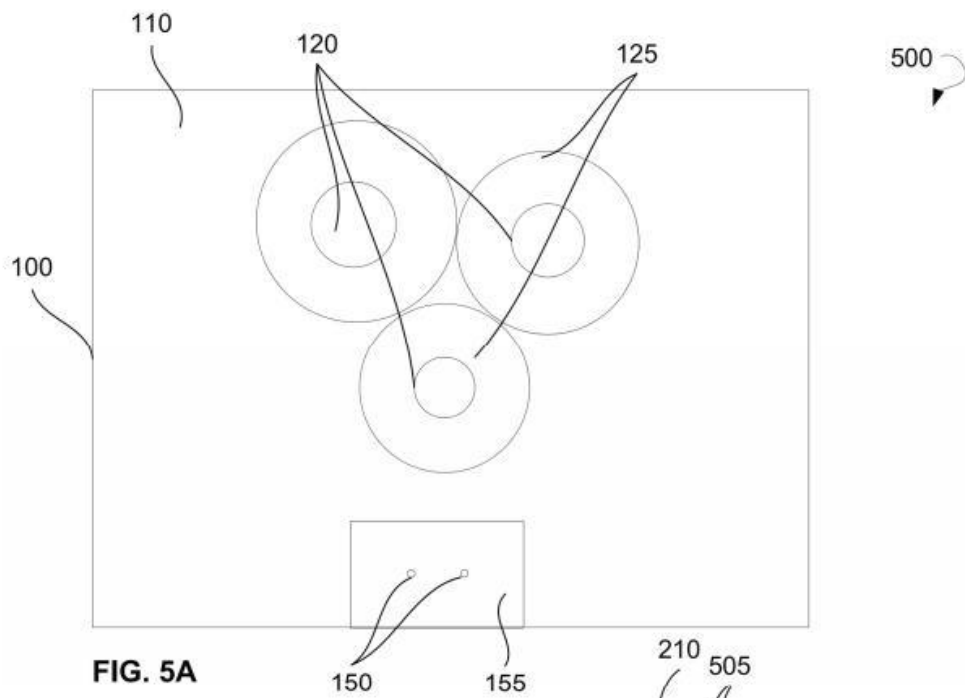
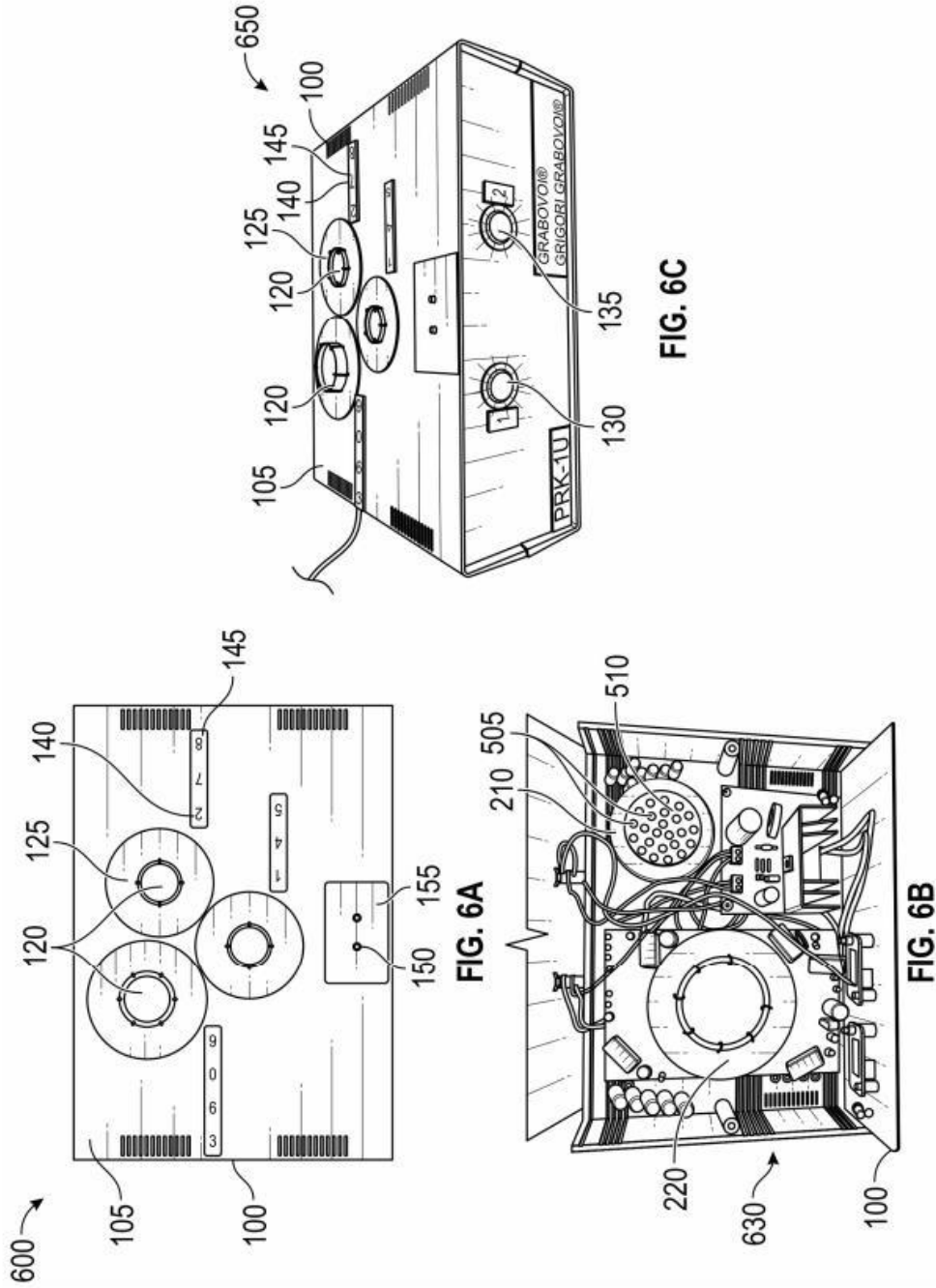

FIG. 4





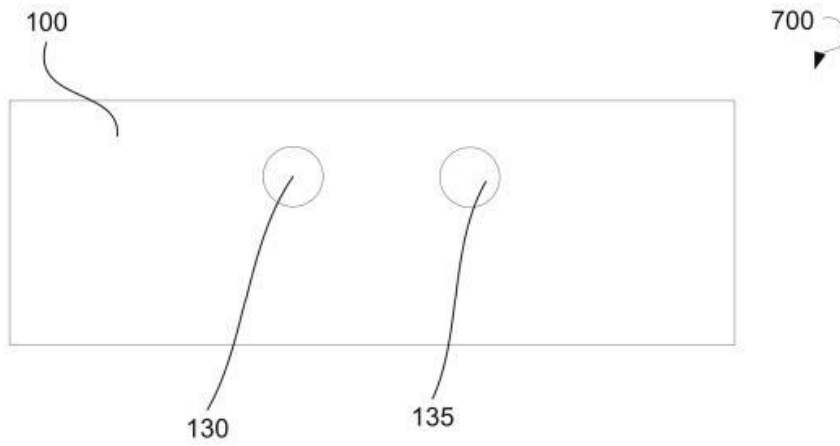

FIG. 7A

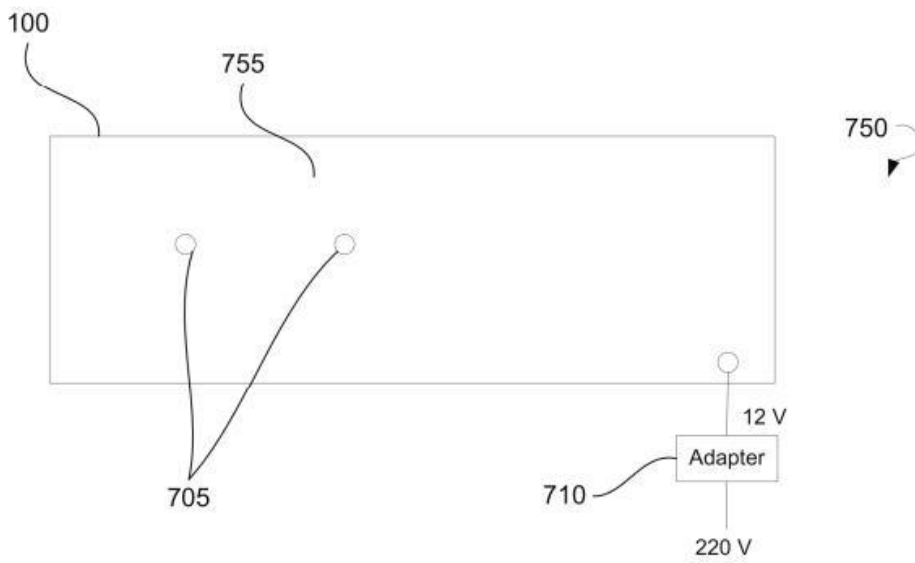

FIG. 7B

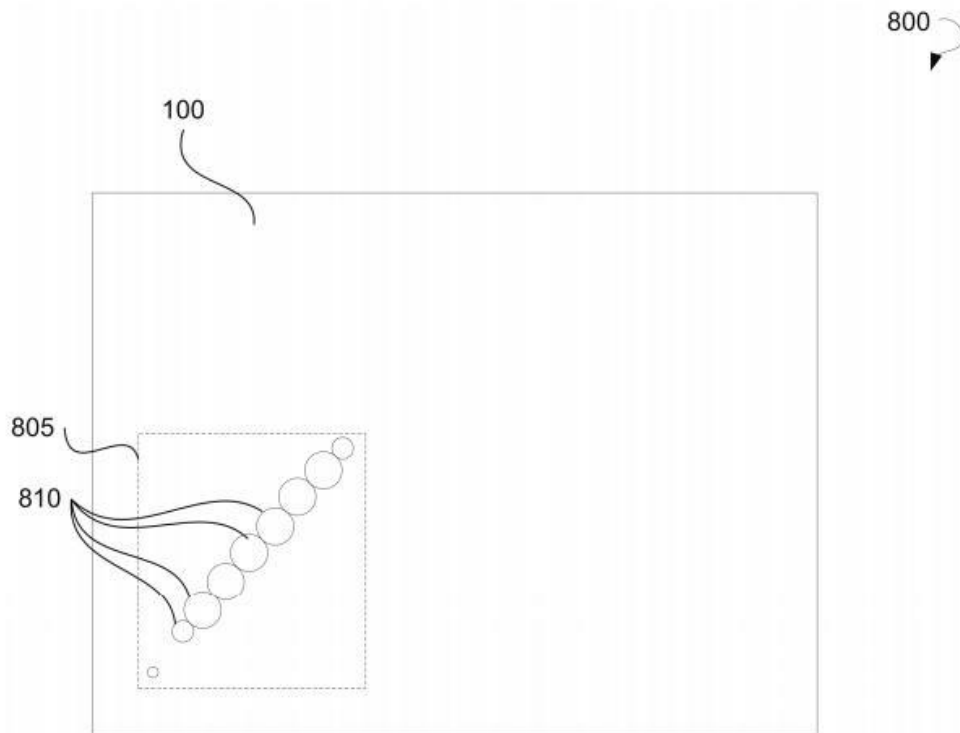

FIG. 8

900

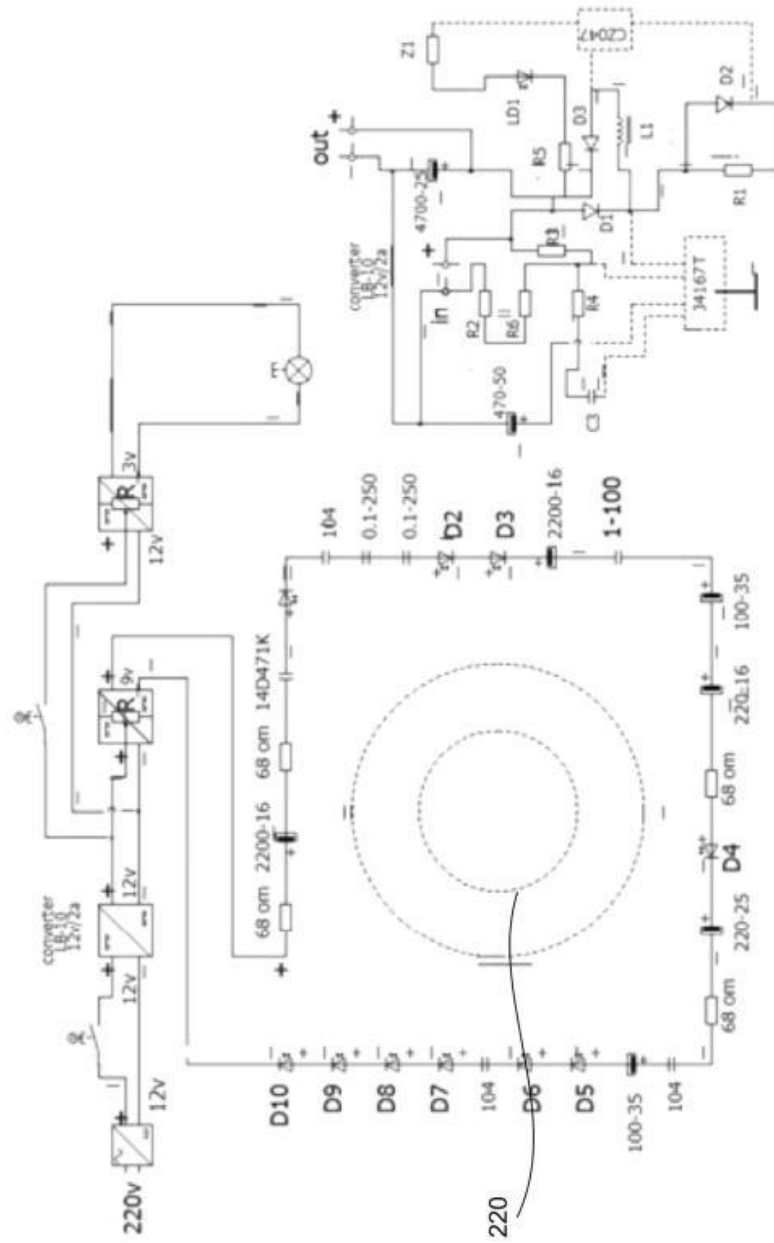

FIG. 9

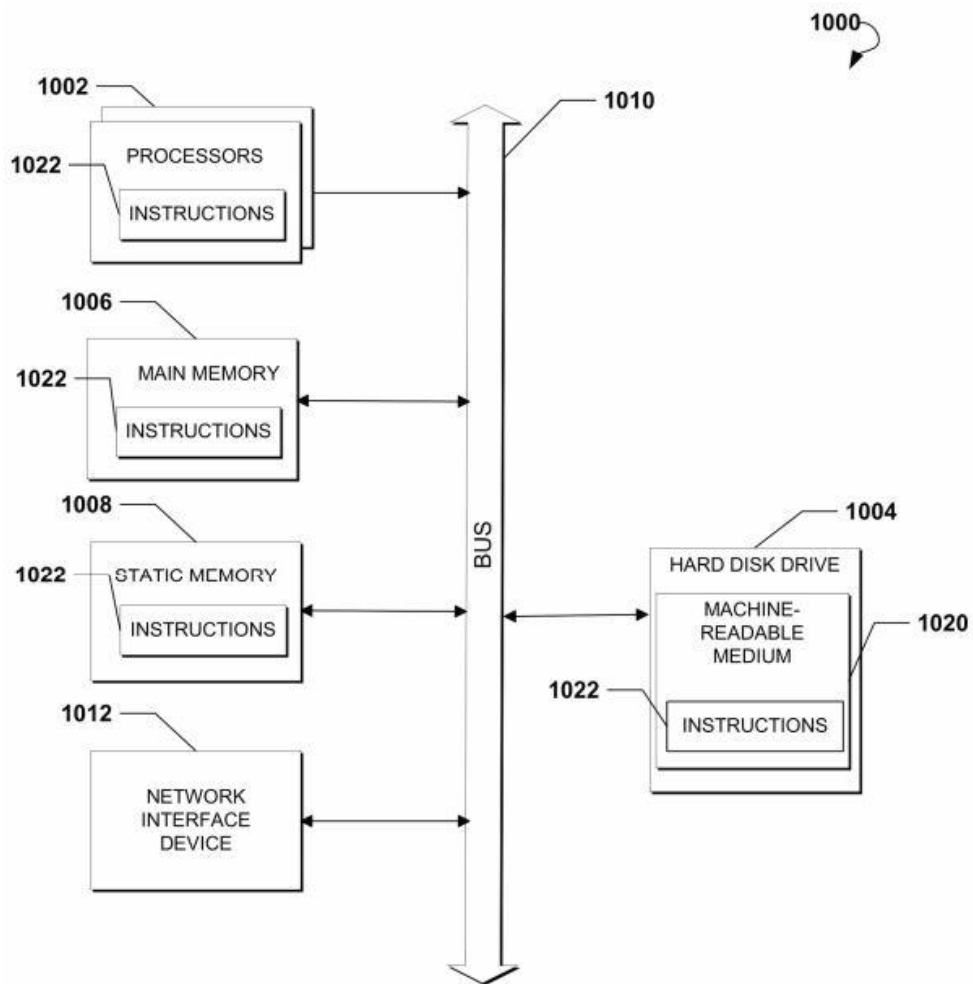

FIG. 10

1

**DEVICE OF DEVELOPMENT OF
CONCENTRATIONS OF ETERNAL LIFE
PRK-1U IS OF THREE-MODES**

CROSS-REFERENCE TO RELATED
APPLICATIONS

This application claims priority of U.S. Provisional Patent Application No. 62/695,756 filed on Jul. 9, 2018, entitled "DEVICE OF DEVELOPMENT OF CONCENTRATIONS OF ETERNAL LIFE PRK-1U IS OF THREE-MODES," which is incorporated herein by reference in its entirety.

TECHNICAL FIELD

The present disclosure relates generally to optical devices and, more specifically, to a device for developing concentration.

BACKGROUND

The approaches described in this section could be pursued but are not necessarily approaches that have previously been conceived or pursued. Therefore, unless otherwise indicated, it should not be assumed that any of the approaches described in this section qualify as prior art merely by virtue of their inclusion in this section.

The variety of devices for sensing and/or determining physical and physiological parameters of a human body increases rapidly. However, the list of vital signs that may be sensed by such devices is mostly limited to a heart rate, blood pressure, blood oxygen level, blood sugar level, body temperature, and some other parameters. Meanwhile, it is generally known that cells of a human body, e.g., neurons, produce electrical activity. In particular, nerve impulses generated by neurons are electrical signals that create electromagnetic fields of the human body. Furthermore, some fluids of the human body are known to act as electrolytes and the flow of such fluids may generate fluctuating electromagnetic fields in the human body. However, conventional electromagnetic sensors are not intended for detecting the electromagnetic fields of the human body and are unable to transform electromagnetic signals emitted by the human body.

SUMMARY

This summary is provided to introduce a selection of concepts in a simplified form that are further described below in the Detailed Description. This summary is not intended to identify key features or essential features of the claimed subject matter, nor is it intended to be used as an aid in determining the scope of the claimed subject matter.

Provided are devices and methods for development of concentration. In some example embodiments, a three-mode device for development of concentration may include an optical sensing unit. The optical sensing unit may include a plurality of sensitive elements. The plurality of sensitive elements may be configured to sense, in one or more of a plurality of operation modes, a signal provided by a user. The signal may be associated with a plurality of electromagnetic fields. The plurality of sensitive elements may be configured to impose, based on the signal, the plurality of electromagnetic fields onto each other to obtain an outgoing signal. The three-mode device for development of concentration may further include an optical emitting unit configured to emit the outgoing signal and one or more lenses for

2

focusing concentration of the user. The one or more lenses may be associated with the optical sensing unit. The three-mode device for development of concentration may further include two switches for switching between the plurality of operation modes and a lighting unit to indicate each of the plurality of operation modes by emitting a predetermined light signal.

A method for development of concentration may commence with providing one or more lenses for focusing the concentration of a user. The one or more lenses may be associated with an optical sensing unit. The method may further include switching between a plurality of operation modes using two switches and indicating, by a lighting unit, each of the plurality of operation modes by emitting a predetermined light signal. The method may continue with sensing, by a plurality of sensitive elements of the optical sensing unit, in one or more of the plurality of operation modes, a signal provided by the user. The signal may be associated with a plurality of electromagnetic fields. The method may continue with imposing, by the optical sensing unit, based on the signal, the plurality of electromagnetic fields onto each other to obtain an outgoing signal. The method may further include emitting, by an optical emitting unit, the outgoing signal.

Additional objects, advantages, and novel features will be set forth in part in the detailed description section of this disclosure, which follows, and in part will become apparent to those skilled in the art upon examination of this specification and the accompanying drawings or may be learned by production or operation of the example embodiments. The objects and advantages of the concepts may be realized and attained by means of the methodologies, instrumentalities, and combinations particularly pointed out in the appended claims.

BRIEF DESCRIPTION OF THE DRAWINGS

Embodiments are illustrated by way of example and not limitation in the figures of the accompanying drawings, in which like references indicate similar elements and in which:

FIG. 1 illustrates a general perspective view of a three-mode device for development of concentration, in accordance with an example embodiment.

FIG. 2 is a block diagram showing various modules of a three-mode device for development of concentration, in accordance with an example embodiment.

FIG. 3 is a schematic diagram illustrating development of concentration of a user using a three-mode device for development of concentration, in accordance with an example embodiment.

FIG. 4 is a flow chart illustrating a method for development of concentration, in accordance with an example embodiment.

FIG. 5A is a schematic diagram illustrating a top view of a three-mode device for development of concentration when a cover is in a closed state, according to an example embodiment.

FIG. 5B is a schematic diagram illustrating a top view of a three-mode device for development of concentration when a cover is in an open state, according to an example embodiment.

FIG. 6A shows a top view of a three-mode device for development of concentration when a cover is in a closed state, according to an example embodiment

3

FIG. 6B shows a top view of a three-mode device for development of concentration when a cover is in an open state, according to an example embodiment.

FIG. 6C shows a general perspective view of a three-mode device for development of concentration, according to an example embodiment.

FIG. 7A shows a front view of a three-mode device for development of concentration, according to an example embodiment.

FIG. 7B is a rear view of a three-mode device for development of concentration, according to an example embodiment.

FIG. 8 shows a top view of a three-mode device for development of concentration, according to an example embodiment.

FIG. 9 is a schematic illustration showing elements of a three-mode device for development of concentration, according to an example embodiment.

FIG. 10 shows a computing system that can be used to implement a method for development of concentration, according to an example embodiment.

DETAILED DESCRIPTION

The following detailed description includes references to the accompanying drawings, which form a part of the detailed description. The drawings show illustrations in accordance with exemplary embodiments. These exemplary embodiments, which are also referred to herein as "examples," are described in enough detail to enable those skilled in the art to practice the present subject matter. The embodiments can be combined, other embodiments can be utilized, or structural, logical, and electrical changes can be made without departing from the scope of what is claimed. The following detailed description is, therefore, not to be taken in a limiting sense, and the scope is defined by the appended claims and their equivalents. In this document, the terms "a" and "an" are used, as is common in patent documents, to include one or more than one. In this document, the term "or" is used to refer to a nonexclusive "or," such that "A or B" includes "A but not B," "B but not A," and "A and B," unless otherwise indicated.

The present disclosure relates to methods and devices for development of concentration. Specifically, the development of concentration is provided by a three-mode device for development of concentration, also referred herein to as a three-mode device PRK-1U for development of concentration. The device may include an optical sensing unit configured to sense signals emitted by a user and an optical emitting unit configured to emit an outgoing signal. The device further includes lenses for focusing concentration of the user, switches for switching between operation modes, and a lighting unit to indicate a current operation mode by emitting a predetermined light signal. The device may further have one or more plates with numerical symbols for focusing the concentration of the user.

The device may include a housing in which elements of the device may be located. The housing may have a parallelepiped shape. The housing may be provided with a cover placed onto the housing to enclose the elements of the device inside the housing. The lenses and plates with numerical symbols for focusing concentration may be attached to an outer surface of the housing or to the cover. The user may be located in proximity to the device. The development of concentration of the user may be provided by focusing user attention on a receiver of the device and controlling the results of the concentration. The lenses and/or the plates

4

with numerical symbols may be configured to be the receiver of concentration of the user. To initiate development of concentration, the user may start concentrating on the lenses and/or the numerical symbols provided on the plates attached to the housing or the cover. Specifically, the user may focus user attention on the lenses and/or the numerical symbols and direct thoughts to the lenses and/or the numerical symbols of the device. The concentration of the user may include thoughts related to providing an eternal life, including concentration on being healthy, concentration on having the quality of control forecasting or control foresight, concentration on rejuvenation, concentration on a particular event in life, and so forth.

As known in psychology, the stronger a person concentrates on a goal, the events in the person's life are optimized and the goal is achieved faster. When concentrating, the user may perform the following actions. The user may imagine user consciousness as a sphere around the user's body informationally supported by the user's body itself. The further action of the user may include imagining that the sphere transforms into a shape similar to the shape of the user's body and then superimposes the shape onto the surface of the user's body. At the moment of superimposing, the user may imagine that the inner surface of the body-like shape comes into contact with the surface of the user's body and that the radiation from the outer's surface of this body-like shape spreads to all external infinite space relative to the user's body. The infinite space is considered to be the eternal reality connected with the organism of the user, which results in development of concentration on eternal life.

The devices and methods described herein are based on the principle of similarity. The principle of similarity is based on the theory of wave synthesis in combination with the unified reality theory (see Ph.D. Thesis in Physical and Mathematical Sciences, G. P. Grabovoi, "Research and Analysis of Fundamental Definitions of Optical Systems for Prediction of Industrial Nature Earthquakes and Disasters", Moscow, RAEN Publishing House, 1999, pp. 9-19; patent of the inventor No. RU 2148845C1 titled "Method of Prevention of Catastrophes and Equipment for its Realization"; and patent of the inventor No. RU 2163419C1 titled "Data Transmission System," which are incorporated herein by reference in their entirety). The devices and methods are further based on physical and mathematical theory, experimental results, physical and mathematical calculations, and the results of these calculations set forth in the publication titled "Research and Analysis of the Fundamental Definitions of Optical Systems in Disaster Prevention and Predictive Microprocessor Control", "Electronic Equipment, Series 3, Microelectronics", 1999, edition 1 (153), and other scientific materials.

In accordance with the wave synthesis theory, reality can be considered as a periodic intersection of stationary regions with dynamic regions, while in the intersection zones a synthesis of a dynamic wave and a stationary wave occurs. Any reality phenomenon can be defined in a form of optical systems. Human perception is performed using image-bearing elements of light that contain information. In case of transmitting information from a person generating information to be transmitted to an optical sensing element, the person may be considered to be a transmitting optical system. The transmitted information generated by thoughts of the person is received by an optical sensing unit to which the person directs the generated thought. As a thought is an electromagnetic wave, it can be transmitted as an element of an optical system. Sensitive elements of the optical sensing

5

unit preferably have the shape of a sphere, as the spherical shape of the sensitive element provides the maximum activation of the sensitive element due to internal reflection of signals. The collection of trial records and testimonies of use of the three-mode device PRK-1U for the development of the concentration is presented in the Appendix of Specification.

The three-mode device for development of concentration performs the imposition of fields from the generation of biological signals and electromagnetic fields (electromagnetic waves generated by the user) according to the principle of universal connection with control of the purpose of concentration. The device further develops concentration of creational control.

In the wave synthesis theory, it is known that a thought generated in a form of radiation simultaneously has two quantum states. The first state is located on a sensing element of a signal transmitter, and the second state is located on a signal receiver. Based on these principles, the device for interacting with thoughts to develop the concentration as described herein was created.

Referring now to the drawings, FIG. 1 is a general perspective view of a three-mode device 100 for development of concentration, hereinafter referred to as a device 100. The device 100 may include a housing 105 and a cover 110. In an example embodiment, the housing 100 may include a box of a rectangular shape. The device 100 may further include lenses 120. The lenses 120 may be attached to an outer surface of the cover 110. In an example embodiment, the lenses 120 may be made of glass. Each of the lenses 120 may be placed on a plate 125 (e.g., a metal plate). The diameter of the lenses 120 may be 20 mm, 25 mm, 60 mm, and any other diameter applicable for a particular embodiment of the device 100. The diameter of the plate 125 may be 60 mm, 64 mm, 70 mm, and any other diameter applicable for a particular embodiment of the device 100.

The device may further have a first switch 130 and a second switch 135 to switch between operation modes of the device 100. The device 100 may have one or more plates 140 with numerical symbols 145 depicted on the plates 140. The device 100 may further have one or more stones 150, such as diamonds, attached to the housing 105 or the cover 110 of the device 100. The stones may be placed on a plate 155. Further elements of the device 100 are shown in detail with reference to FIGS. 2-9.

FIG. 2 is a block diagram showing various units of a three-mode device 100 for development of concentration, in accordance with certain embodiments. Specifically, the device 100 may include an optical sensing unit 210, optical emitting unit 220, one or more lenses 230, two switches 240, and a lighting unit 250. The one or more lenses 230 for focusing concentration of a user may be associated with the optical sensing unit 210. The device 100 may further include a housing and a cover. The one or more lenses 230 may be disposed on the cover.

The optical sensing unit 210 may have a plurality of sensitive elements. In an example embodiment, the plurality of sensitive elements may be spherical. In an example embodiment, the sensitive elements may be made of glass. The plurality of sensitive elements may be configured to sense a signal provided by the user. The sensitive elements may sense the signal in one or more of a plurality of operation modes of the device 100. The signal may be associated with a plurality of electromagnetic fields. The signal provided by the user may be a biological signal. The biological signal may include an electromagnetic wave associated with thoughts generated by the user when con-

6

centrating on the one or more lenses 230 for focusing concentration. Specifically, the information (signal) may be generated in a form of electromagnetic radiation by the user. The user concentrates the electromagnetic radiation created by thought on the one or more lenses 230 located on the upper surface of the device 100.

The plurality of sensitive elements may be further configured to impose, based on the signal, the plurality of electromagnetic fields onto each other to obtain an outgoing signal. The optical emitting unit may be configured to emit the outgoing signal. In an example embodiment, the optical emitting unit 220 may include an optical lens. In an example embodiment, the optical lens may be made of glass. The optical emitting unit 220 may emit the outgoing signal in a form of at least an optical signal. In an example embodiment, the device 100 may include a further plurality of sensitive elements. The further plurality of sensitive elements may include crystals and stones, such as diamonds.

The two switches 240 may be used for switching between the plurality of operation modes of the device 100. The lighting unit 250 may be configured to indicate each of the plurality of operation modes of the device 100 by emitting a predetermined light signal. Specifically, the plurality of operation modes may include at least three modes. A first operation mode may be turned on by moving a first switch of the two switches 240 into an upward position. The first operation mode may be characterized by absence of emittance of a light signal by the lighting unit 250. A second operation mode may be turned on by moving a second switch of the two switches into an upward position. The second operation mode may be characterized by emittance of a static light signal by the lighting unit 250. A third operation mode may be turned on by moving the first switch into a downward position and further moving the first switch into an upward position while the second switch remains in the upward position. The third operation mode may be characterized by emittance of a repetitively-pulsed light signal by the lighting unit 250.

In an example embodiment, the two switches 240 may be made of a transparent or semi-transparent material, such as glass or plastics. The device 100 may have a light emitting diode (LED) disposed inside the housing for emitting the light signal. When the LED emits light inside the device 100, the light emitted from inside of the device 100 can be seen through the two switches 240. Upon switching between the operation modes, the LED may not emit light, may continuously emit light (i.e., provide the static light signal), and may repetitively emit light (i.e., provide the repetitively-pulsed light signal).

The signal provided by the user may be sensed in each of the operation modes. For example, the device 100 may be switched to the second operation mode and the optical sensing unit 210 may sense the signal provided by the user when the device 100 operates in the second operation mode. In an example embodiment, the device 100 may be switched to the third operation mode and the optical sensing unit 210 may sense the signal provided by the user when the device 100 operates in the third operation mode. The operation modes of the device 100 may be used to increase the concentration on the user.

In an example embodiment, the device 100 may further include a plurality of figures placed on the housing and/or the cover of the device 100. The figures may include numerical symbols for focusing the concentration of the user. The numerical symbols may be depicted on plates (e.g., metal, plastics, paper, wooden plates, etc.), which can be attached to the housing and/or the cover of the device 100.

The numerical symbols depicted on the plates may be used for focusing the concentration of the user.

In an example embodiment, the device 100 may further include a converting unit configured to convert the outgoing signal into an electrical signal. In an example embodiment, the converting unit may be connected to a processing unit. The processing unit may be in communication with the optical sensing unit 210, the optical emitting unit 220, and the lighting unit 250 and perform processing of sensed signals, imposed signals, optical signals, and outgoing signals. The device 100 may further include a power source in communication with the optical sensing unit 210, the optical emitting unit 220, and the lighting unit 250.

In the publication titled "Research and Analysis of the Fundamental Definitions of Optical Systems in Disaster Prevention and Predictive Microprocessor Control," "Electronic Equipment, Series 3, Microelectronics," 1999, edition 1 (153), the inventor proves the unified reality theory and the theory of wave synthesis. According to the unified reality theory and the theory of wave synthesis, the second operation mode results in applying the amplification of the stationary phase of the reality. Furthermore, according to the unified reality theory and the theory of wave synthesis, the third operation mode results in applying the amplification of the dynamic phase of reality.

The technique of providing eternal life can work according to the principle similar to principles of functioning of the human body in the field of thinking. According to the principle of functioning of the human body when creating thoughts, the physical body of a person consists of the same tissues that do not change in the process of thinking, but thoughts that are created in the physical body are different. In the three-mode device 100 for development of concentration, the similarity principle is applied, which is illustrated by the fact that the same two buttons (i.e., switches) are used to activate the third operation mode for amplification of the dynamic phase of the reality. In other words, no elements are added to the device 100 just as no elements are added to the human body when a new thought is created. The third operation mode is turned on by turning the first switch off and on (to the downward and upward position) again while the second switch remains in the upward position. Therefore, switching between three operation modes may be provided by two switches.

Thus, by using the unified reality theory and the theory of wave synthesis proved by physical and mathematical calculations and experiments, the components are selected and an electrical scheme is developed for the device 100 so that the device 100 is similar to a human body in the following sense. A human body generates thoughts without adding any matter (components) to the human body. Similarly, the device 100 autonomously, without adding further switches, i.e., in a closed system, generates the third operation mode for amplification of the dynamic phase of the reality, which is illustrated by the repetitively-pulsed light emittance. In other words, the element base of the device 100 has a self-development function similar to that in the human body. This function of the device 100, due to the interaction of the components of the device 100, itself includes the activation of the operation mode for repetitively-pulsed light emittance. This allows the development of concentration when using the device 100, as the preceding level of developing the concentration, including that achieved with the help of the device 100 itself, is always the starting point for further development of concentration.

The work with the device 100 in different operation modes provides extensive results on the development of

concentration, which is required in many areas of life, including production, operational activity, and other activities in industrial fields.

The device 100 may further be configured to activate an artificial intelligence function. This function enables the device 100, depending on the activity of generation of thoughts by the user and depending on the degree of development of concentration on eternal life in respect to specific events, to independently switch off the operation modes of the device 100 and then, after a time period determined by the device 100, again switch on any of three operation modes. Accordingly, the procedure of activation of this artificial intelligence function was developed.

The device 100 provides the capability to combine three modes of operation, thereby creating better concentration on ensuring eternal life.

FIG. 3 is a schematic diagram 300 illustrating development of concentration of a user using a three-mode device 100 for development of concentration, according to an example embodiment. A user 305 may be located in a proximity of the device 100. The user 305 may concentrate user attention on lenses 120 and/or numerical figures 145 of the device 100. The lenses 120 may have different diameters. By concentrating, the user 305 generates thoughts, which are electromagnetic signals 310. The thoughts may contain the purpose of concentration, such as concentration on eternal life, concentration on being healthy, concentration on having the quality of control forecasting or control foresight, concentration on rejuvenation, and so forth. The action of concentration for the current time and future time may be performed with respect to a sensing element of the optical emitting unit consisting of lenses. The user 305 may perform circular movements associated with the concentration (i.e., direct thoughts) by following a direction from a lens of a smaller diameter counterclockwise to lenses of a larger diameter. In the case of concentrations related to the current time and future time, a concentration beam may be directed in a direction from outside of the device 100 to an inner space of the device 100.

If the concentration of the user 305 relates to past events, the user 305 may perform circular movements associated with the concentration by following a direction from a lens of a smaller diameter clockwise to lenses of a larger diameter. The concentration beam may be directed in a direction from inside the device 100 to an outside space.

In accordance with the information transmission on the basis of the wave synthesis theory, another quantum state of thoughts may be projected on a signal receiver in a form of an optical emitting unit located inside the device 100.

FIG. 4 is a process flow diagram showing a method 400 for development of concentration, according to an example embodiment. In some embodiments, the operations may be combined, performed in parallel, or performed in a different order. The method 400 may also include additional or fewer operations than those illustrated.

The method 400 may commence with providing one or more lenses for focusing concentration of a user at operation 402. The lenses may be associated with an optical sensing unit. The method 400 may continue with switching between a plurality of operation modes using two switches at operation 404. Operation 406 of the method 400 may include indicating, by a lighting unit, each of the plurality of operation modes by emitting a predetermined light signal.

The method 400 may further include sensing, by a plurality of sensitive elements of the optical sensing unit, in one or more of the plurality of operation modes, a signal provided by the user at operation 408. The signal may be

associated with a plurality of electromagnetic fields. The plurality of sensitive elements may be spherical. The signal provided by the user may be a biological signal.

The method 400 may further include imposing, based on the signal, by the optical sensing unit, the plurality of electromagnetic fields onto each other to obtain an outgoing signal at operation 410. Specifically, the method 400 may be performed by using signal conditioning by imposing electromagnetic fields resulting from the generation of a biological signal to each other. The method 400 may be performed in accordance with the principle of universal connection with control of the purpose of concentration, which can be developed according to techniques described by the inventor in the publications mentioned herein.

The method 400 may further include emitting, by an optical emitting unit, the outgoing signal at operation 412. The optical emitting unit may include an optical lens. The optical emitting unit may emit the outgoing signal in the form of at least an optical signal. The method 400 may further include converting, by a converting unit, the outgoing signal into an electrical signal.

In an example embodiment, the method 400 may further include providing a power source. The power source may be in communication with the optical sensing unit and the optical emitting unit. In an example embodiment, the method 400 may further include providing a housing and a cover. The one or more lenses may be disposed on the cover.

FIG. 5A shows a top view 500 of a device 100 when a cover 100 is in a closed state, according to an example embodiment. The device 100 may have three plates 125 on which lenses 120 may be fastened. The plates 125 may be attached to the cover 120. The device 100 may further have a plate 155 for fastening stones 150, such as crystals or diamonds. The plate 155 may be attached to the cover 110.

FIG. 5B shows a top view 500 of the device 100 when the cover 100 is in an open state, according to an example embodiment. The device 100 may include an optical sensing unit 210, a plurality of sensitive elements 505, an optical emitting unit 220, a LED 510, and a converter 515. The plurality of sensitive elements 505 of the optical sensing unit 210 may sense the signal emitted by the user and provide the signal to the converter 515. The converter 515 may convert the signal into an electrical signal. The converter 515 may provide the electrical signal to the LED 510. The LED 510 may be electrically connected in parallel with other components of the device 100. Upon receipt of the electrical signal, the LED 510 may emit the electrical signal in the form of a light signal according to a current operation mode of the device 100.

The signal sensed by the plurality of sensitive elements 505 may be associated with a plurality of electromagnetic fields. The optical sensing unit 210 may impose the plurality of electromagnetic fields onto each other to obtain an outgoing signal. The optical sensing unit 210 may provide the outgoing signal to the optical emitting unit 220 for further emission of the outgoing signal by the optical emitting unit 220.

FIG. 6A shows a top view 600 of the device 100 when the cover is in a closed state, according to an example embodiment. The device 100 may have three plates 125 onto which lenses 120 may be fastened. The plates 125 may be attached to the cover. The device 100 may further have a plate 155 for fastening stones 150, such as crystals or diamonds. The plate 155 may be attached to the cover. The device 100 may have one or more plates 140 with numerical symbols 145 depicted on the plates 140.

In a further example embodiment, the device 100 may have concentration enhancement elements. The concentration enhancement elements may be used for enhancing and accelerating the development of concentration. The concentration enhancement elements may include crystals and stones 150, e.g., diamonds or rock crystals.

FIG. 6B shows a top view 630 of the device 100 when the cover is in an open state, according to an example embodiment. The device 100 may include an optical sensing unit 210, a plurality of sensitive elements 505, an optical emitting unit 220, and a LED 510.

FIG. 6C further shows a general perspective view 650 of the device 100, according to an example embodiment. The device 100 may include a first switch 130 and a second switch 135. The first switch 130 and the second switch 135 may be made of a transparent material, such as glass or plastic. When the LED 510 emits light inside the device 100, the light emitted from inside of the device 100 can be seen through the first switch 130 and the second switch 135.

In an example embodiment, figures may be placed on the cover in the form of numerical values 145. For example, figures 1, 4, 5 may be placed (e.g., written) near a smaller lens, and figures 2, 7, 8, and 9, 0, 6, 3 may be placed near larger lenses. The development of concentration using the presence of figures near the lenses can be made by concentrating on the lenses in a way described above and adding concentration on the figures.

FIG. 7A shows a front view 700 of the device 100, according to an example embodiment. The device 100 may have a first switch 130 and a second switch 135. Each of the first switch 130 and the second switch 135 may be configured to operate in several positions. Specifically, the first switch 130 may be moved into an upward position to switch to a first operation mode. The second switch 135 may be moved into an upward position to switch to a second operation mode. The first switch 130 may be moved into a downward position and further moved into the upward position to switch a third operation mode.

FIG. 7B shows a rear view 750 of the device 100, according to an example embodiment. The device 100 may have controlling elements 705 disposed in adjustment holes in the housing of the device 100 for tuning components of the device 100 using a side panel 755. The device 100 may be in communication with an adapter 710. The adapter 710 may be configured to convert the voltage of 220 V from a power grid into the voltage of 12 V consumed by the device 100.

FIG. 8 shows a top view 800 of the device 100, according to an example embodiment. The device 100 may further include one or more crystal systems 805. The crystal system 805 may consist of a plurality of crystals 810. The crystals 810 may be used for focusing the concentration of the user. The crystal system 805 may be a vertical crystal system in which the crystals 810 may have different radii and, hence, different heights. The radius of the crystals 810 may be 7 mm, 12 mm, and so forth.

In an example embodiment, the three-mode device for development of concentration may be used remotely through video monitoring of the device by a user, including via the Internet. The three-mode device for development of concentration is applicable in various areas related to providing eternal life, such as becoming healthy, developing the quality of control forecasting or control foresight, rejuvenating an organism, and so forth.

FIG. 9 is a schematic diagram 900 illustrating a three-mode device for development of concentration, according to an example embodiment. The elements shown on FIG. 9

may be located inside a housing of the three-mode device for development of concentration. The three-mode device for development of concentration may include an optical emitting unit 220.

Example 1 of operation of a three-mode device for development of concentration. On day 1, a first user turned the three-mode device off and then turned on after some period of time. Upon being turned on, the three-mode device entered the first operation mode, in which a red light mostly did not light up, meaning that power provided to the diode was low. Upon switching the three-mode device manually to the second and third operation modes, the three-mode device did not react, i.e., did not switch to the second and third operation modes.

The three-mode device is configured for developing concentrations on eternal life. The three-mode device can switch to one of the operation modes upon increasing the control load. In view of this, four users started a concentration session using the three-mode device by concentrating on lenses for focusing concentration of the users.

Three days later, the three-mode device entered the second operation mode. The three-mode device worked stably, but the third mode could not be turned on. Four users continued performing concentration sessions during the next three days. The three-mode device was placed in a room of the first user during the time when the concentration sessions were performed.

After three days, the second user took the three-mode device to work in a room of the second user. The three-mode device was moved to the room and turned on. The second user continued performing the concentration session using the three-mode device by concentrating on lenses for focusing concentration of the users. Upon turning on, the three-mode device began to self-adjust as was seen from diode heating. In a few seconds, the three-mode device entered the third operation mode and began to work stably in all three operation modes.

After three hours of operation, the three-mode device was again transferred to a room of the first user and turned on. The first user continued performing the concentration session using the three-mode device by concentrating on lenses for focusing concentration of the users. Upon turning on, the three-mode device worked in the third operation mode. At the time of turning on of the three-mode device, the first user was located in proximity to the three-mode device and had a conversation and was distracted from the concentration session. In a several minutes, the three-mode device automatically switched to the second operation mode. When the third operation mode was manually turned on, the device did not respond. Then, the three-mode device was unplugged and moved to the room of the second user, where it worked steadily before. Upon being turned on, the three-mode device immediately entered the third operation mode and there were no failures in operation of the three-mode device. The three-mode device worked stably in all three modes. After this check, the three-mode device was again transferred to the room of first user and turned on. The three-mode device did not work in the third operation mode in the room of the first user. Then, the operation of the three-mode device was re-tested in the room of the second user. The three-mode device was moved to the room of the second user and turned on. The three-mode device consistently entered all the three operation modes. The operation of the three-mode device was recorded by photographing the device. Each of the first user and the second user continued performing the concentration session using the three-mode device when the three-mode device was in the room of each

of the users. Then, the three-mode device was turned off, moved again to the room of the first user, and turned on. The first user continued the concentration session by concentrating on lenses of the three-mode device. Upon turning on, the three-mode device entered all the three operation modes and began to work stably in all operation modes.

Thus, the three-mode device independently switches to one of the operation modes in response to the signals received from the users during the concentration sessions. This function of artificial intelligence of the three-mode device, i.e. automatic switching between the modes, is turning on in case of simultaneous receipt of an increased amount of signals, e.g., from several users.

Example 2 of operation of a three-mode device for development of concentration. A user travelled to a foreign country and had a 24 hours long layover between the flights. The user experienced strong emotions during the layover, such as intensive fear, worry, lack of self-confidence, and perplexity. The user arrived at the hotel during the layover, turned the three-mode device, and started a first concentration session by concentrating on lenses of the three-mode device. Upon switching on, the three-mode device operated in the third operation mode and did not respond to manual switching of the three-mode device by the user to the second operation mode or the first operation mode. The next day, the user had a flight to the foreign country and an emotional state of the user stabilized, i.e. the user had a normal emotional state. When the user arrived at the hotel, the user turned the three-mode device and started a second concentration session by concentrating on lenses of the three-mode device. Upon switching on, the three-mode device operated in the first operation mode. The user manually switched the three-mode device to the second operation mode and then to the third operation mode. The three-mode device responded to switching between the modes by the user and switched to the second operation mode or the third operation mode, respectively. It was concluded that the user had intensive emotions and thoughts during the first concentration session. In view of this, the intensity of a signal transmitted by the user to the three-mode device caused automatic switching of the three-mode device to the third operation mode, in which the three-mode device amplified the dynamic phase of reality.

Example 3 of operation of a three-mode device for development of concentration. A user conducted concentration sessions using the three-mode device for four days in a first city. The three-mode device operated properly and responded to switching between the operation modes by the user by operating in a first operation mode, a second operation mode, or the third operation mode, respectively. On day five, the user moved to a second city and, upon arrival, started a concentration session. The user turned the three-mode device on. The three-mode device operated in the first operation mode. The user attempted to manually switch the three-mode device to the second operation mode. In response to the attempt of the user, the three-mode device switched to the third operation mode and did not respond to further attempts of the user to switch the three-mode device to the second operation mode. The automatic switching of the three-mode device to the third operation mode continued in the course of concentration sessions conducted by the user during seven days. During this seven-day period, the user had intensive emotions and thoughts when conducting the concentration sessions. In view of this, the intensity of a signal transmitted by the user to the three-mode device caused automatic switching of the three-mode device to the third operation mode, in which the three-mode device ampli-

fied the dynamic phase of reality. After seven days, the emotional state of the user stabilized and the three-mode device started operating normally and responded to manual switching of the three-mode device by the user to the second operation mode or the third operation mode.

FIG. 10 shows a diagrammatic representation of a computing device for a machine in the exemplary electronic form of a computer system 1000, within which a set of instructions for causing the machine to perform any one or more of the methodologies discussed herein can be executed. In various exemplary embodiments, the machine operates as a standalone device or can be connected (e.g., networked) to other machines. In a networked deployment, the machine can operate in the capacity of a server or a client machine in a server-client network environment, or as a peer machine in a peer-to-peer (or distributed) network environment. The machine can be a personal computer (PC), a tablet PC, a set-top box, a cellular telephone, a digital camera, a portable music player (e.g., a portable hard drive audio device, such as a Moving Picture Experts Group Audio Layer 3 (MP3) player), a web appliance, a network router, a switch, a bridge, or any machine capable of executing a set of instructions (sequential or otherwise) that specify actions to be taken by that machine. Further, while only a single machine is illustrated, the term "machine" shall also be taken to include any collection of machines that individually or jointly execute a set (or multiple sets) of instructions to perform any one or more of the methodologies discussed herein.

The computer system 1000 may include a processor or multiple processors 1002, a hard disk drive 1004, a main memory 1006 and a static memory 1008, which communicate with each other via a bus 1010. The computer system 1000 may also include a network interface device 1012. The hard disk drive 1004 may include a computer-readable medium 1020, which stores one or more sets of instructions 1022 embodying or utilized by any one or more of the methodologies or functions described herein. The instructions 1022 can also reside, completely or at least partially, within the main memory 1006 and/or within the processors 1002 during execution thereof by the computer system 1000. The main memory 1006 and the processors 1002 also constitute machine-readable media.

While the computer-readable medium 1020 is shown in an exemplary embodiment to be a single medium, the term "computer-readable medium" should be taken to include a single medium or multiple media (e.g., a centralized or distributed database, and/or associated caches and servers) that store the one or more sets of instructions. The term "computer-readable medium" shall also be taken to include any medium that is capable of storing, encoding, or carrying a set of instructions for execution by the machine and that causes the machine to perform any one or more of the methodologies of the present application, or that is capable of storing, encoding, or carrying data structures utilized by or associated with such a set of instructions. The term "computer-readable medium" shall accordingly be taken to include, but not be limited to, solid-state memories, optical and magnetic media. Such media can also include, without limitation, hard disks, floppy disks, NAND or NOR flash memory, digital video disks, Random Access Memory, Read-Only Memory, and the like.

The example embodiments described herein may be implemented in an operating environment comprising software installed on a computer, in hardware, or in a combination of software and hardware.

Thus, three-mode devices and methods for development of concentration are described. Although embodiments have been described with reference to specific exemplary embodiments, it will be evident that various modifications and changes can be made to these exemplary embodiments without departing from the broader spirit and scope of the present application. Accordingly, the specification and drawings are to be regarded in an illustrative rather than a restrictive sense.

What is claimed is:

1. A three-mode device for development of concentration, the device comprising:
 - a housing;
 - a first optical unit disposed in the housing, the first optical unit comprising a plurality of spherical elements;
 - a second optical unit disposed in the housing wherein the second optical unit includes an optical lens;
 - one or more lenses for enabling a user to affix a user gaze on the one or more lenses;
 - one or more plates attached to the housing, wherein the one or more lenses are placed on the one or more plates, wherein a diameter of the one or more plates exceeds a diameter of the one or more lenses;
 - two switches for switching between a plurality of operation modes associated with emittance of a predetermined light signal, the two switches being disposed on the housing; and
 - a lighting unit disposed in the housing and configured to indicate each of the plurality of operation modes by emitting the predetermined light signal.
2. The device of claim 1, further comprising a cover.
3. The device of claim 2, further comprising a plurality of figures placed on one of the housing and the cover, wherein the plurality of figures includes numerical symbols.
4. The device of claim 2, wherein the one or more lenses are disposed on the cover.
5. The device of claim 1, further comprising a power source in communication with the lighting unit.
6. The device of claim 1, wherein the plurality of operation modes includes:
 - a first operation mode configured to be turned on by moving a first switch of the two switches into an upward position, the first operation mode being characterized by absence of emittance of a light signal by the lighting unit;
 - a second operation mode configured to be turned on by moving a second switch of the two switches into an upward position, the second operation mode being characterized by emittance of a static light signal by the lighting unit; and
 - a third operation mode configured to be turned on by moving the first switch into a downward position and further moving the first switch into the upward position, the third operation mode being characterized by emittance of a repetitively-pulsed light signal by the lighting unit.
7. The device of claim 1, wherein the plurality of spherical elements are made of glass.
8. The device of claim 1, wherein the optical lens is made of glass.
9. The device of claim 1, further comprising a further plurality of optical elements, wherein the further plurality of optical elements are selected from crystals and stones.
10. A method for development of concentration, the method comprising:
 - providing a housing;

15

providing a first optical unit disposed in the housing, the first optical unit comprising a plurality of spherical elements;

providing a second optical unit disposed in the housing, wherein the second optical unit includes an optical lens;

providing one or more lenses for enabling a user to affix a user gaze on the one or more lenses;

providing one or more plates, wherein the one or more lenses are placed on the one or more plates, wherein a diameter of the one or more plates exceeds a diameter of the one or more lenses;

switching between a plurality of operation modes using two switches disposed on the housing, the plurality of operation modes being associated with emittance of a predetermined light signal; and

indicating, by a lighting unit disposed in the housing, each of the plurality of operation modes by emitting the predetermined light signal.

11. The method of claim 10, further comprising providing a power source, wherein the power source is in communication with the lighting unit.

12. The method of claim 10, further comprising providing a cover.

13. The method of claim 12, further comprising providing a plurality of figures, wherein the plurality of figures includes numerical symbols placed on one of the housing and the cover.

14. The method of claim 12, wherein the one or more lenses are disposed on the cover.

15. A three-mode device for development of concentration, the device comprising:

- a housing;
- a first optical unit disposed in the housing, the first optical unit comprising a plurality of optical elements, wherein the plurality of optical elements are made of glass;

16

a second optical unit disposed in the housing, wherein the second optical unit includes an optical lens;

one or more lenses for enabling a user to affix a user gaze on the one or more lenses, the one or more lenses being made of glass;

one or more plates attached to the housing, wherein the one or more lenses are placed on the one or more plates, wherein a diameter of the one or more plates exceeds a diameter of the one or more lenses;

two switches for switching between a plurality of operation modes associated with emittance of a predetermined light signal, the two switches being disposed on the housing; and

a lighting unit disposed in the housing and configured to indicate each of the plurality of operation modes by emitting the predetermined light signal, wherein the plurality of operation modes includes:

a first operation mode configured to be turned on by moving a first switch of the two switches into an upward position, the first operation mode being characterized by absence of emittance of a light signal by the lighting unit;

a second operation mode configured to be turned on by moving a second switch of the two switches into an upward position, the second operation mode being characterized by emittance of a static light signal by the lighting unit; and

a third operation mode configured to be turned on by moving the first switch into a downward position and further moving the first switch into the upward position, the third operation mode being characterized by emittance of a repetitively-pulsed light signal by the lighting unit.

* * * * *

Sertifikati o registraciji industrijskog dizajna uređaja PRK-1UM

U Velikoj Britaniji (Zavod za intelektualnu svojinu)



Intellectual
Property
Office

Certificate of Registration for a UK Design

Design number: 6406099

Grant date: 30 November 2024

Registration date: 20 November 2024

This is to certify that,

in pursuance of and subject to the provision of Registered Designs Act 1949, the design of which a representation or specimen is attached, had been registered as of the date of registration shown above in the name of

Grigorii Petrovich Grabovoi

in respect of the application of such design to:

smart projectors

International Design Classification:

Version: 14-2023

Class: 16 PHOTOGRAPHIC, CINEMATOGRAPHIC AND OPTICAL APPARATUS

Subclass: 02 PROJECTORS AND VIEWERS

A handwritten signature in black ink that reads "Adam Williams".

Adam Williams

Comptroller-General of Patents, Designs and Trade Marks

Intellectual Property Office

The attention of the Proprietor(s) is drawn to the important notes overleaf.



Intellectual Property Office is an operating name of the Patent Office

www.gov.uk/ipo

Representation of Designs







Intellectual Property Office is an operating name of the Patent Office

www.gov.uk/ipo

U Belgiji, Holandiji, Luksemburgu (Beneluks (BOIP))

2024-06-11 13:27

Search or retrieve a design



Copy of the Designs Register

Registration number

90582-01

Number, date and hour of application

90582-01 10-06-2024, 10.31

Date of registration

11-06-2024

Expiration date

10-06-2029

Name and address of the holder

Grigorii Petrovich Grabovoi

Ulica Kneza Mihaila 21A, lok.113

11102 Belgrad

Serbia

Representative or postal address of holder

Fenix Legal KB

Östermalmstorg 1,3tr

11442 Stockholm

Sweden

Reproduction of design

SEE REPRODUCTION(S)

Indication of a product followed by the class(es) and subclass(es)

Smart projectors (cl 16-02).

Indication of the creator of the design

Grigorii Petrovich GRABOVOI

Date of publication of registration

11-06-2024

Status

Registered

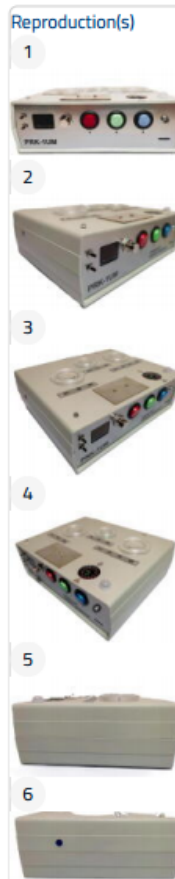

U Švajcarskoj (Švajcarski savezni institut za intelektualnu svojinu)



Eidgenössisches Institut für Geistiges Eigentum
Institut Federal de la Propriete Intellectuelle
Istituto Federale della Proprietà Intellettuale
Swiss Federal Institute of Intellectual Property

Stauffacherstrasse 65/59 g
CH-3003 Bern
T +41 31 377 77 77
info@ipi.ch | ww.ige.ch

Swissregauszug - Designs

Stand vom 24.12.2024

Designnummer	148367
Gesuchsnummer	2024-00556
Hinterlegungsdatum	21.11.2024
Eintragungsdatum	23.12.2024
Publikationsdatum	23.12.2024
Schutzperiode bezahlt bis	21.11.2029
Maximale Schutzdauer	21.11.2049

Intelligente Projektoren

Inhaber/in

Grigorii Petrovich Grabovoi
Ulica Kneza Mihaila 21A, lok.113
11102 Belgrad
Serbien

Designer/in

Grigorii Petrovich Grabovoi
11102 Belgrad
Serbien

Bezeichnung

Intelligente Projektoren

Locarno Klassifikation

16-02

Hinterlegungsart

Einzelhinterlegung

Anzahl Hinterlegungen

1

Hinterlegungen

Reproduktion

Ordnungsnummern

1

Prioritäten

BX 90582-01 10.06.2024

1/3

02.01.2025

148367

Designbilder

Ordnungsnummer: 1



Abbildung Nr.: 1/6



Abbildung Nr.: 2/6



Abbildung Nr.: 3/6



Abbildung Nr.: 4/6



Abbildung Nr.: 5/6



Abbildung Nr.: 6/6

Historie

23.12.2024

Eintragung

Veröffentlicht in Swissreg am 23.12.2024

Schutztitelstadium

Eingetragen

Designnummer

148367

Eintragungsdatum

23.12.2024

Publikationsdatum

23.12.2024

Schutztitelstadium

~~Gesuch~~

Designnummer

Eintragungsdatum

Publikationsdatum

U Nemačkoj (Deutsches Patent- und Markenamt)

🇩🇪 Bundesrepublik Deutschland 🇩🇪

Urkunde

über die Eintragung des
Designs Nr. 402024100406-0001



Darstellung 1 von 6

Inhaber/Inhaberin:
Grigori Petrovich Grabovoi, Belgrad, RO

Tag der Anmeldung:
10.06.2024

Tag der Eintragung:
12.11.2024

Die Präsidentin des Deutschen Patent- und Markenamts

Eva Schewior

Eva Schewior

München, 12.11.2024



Die Voraussetzungen der Schutzfähigkeit werden bei der Eintragung eines Designs nicht geprüft.
Den aktuellen Rechtsstand und Schutzzumfang entnehmen Sie bitte dem DPMAregister unter www.dpma.de.



Auskunft zum Design 402024100406-0001

Stand am 13.01.2025

Es bestehen folgende Eintragungen:

Stammdaten

- [19] **Datenbestand:** DE
[----] **Bestandsart:** Aktiv
[----] **Designnummer:** 402024100406-0001
[21] **Aktenzeichen:** 402024100406.6
[11] **Registernummer:** 402024100406
[----] **Designzustand:** Design eingetragen
[----] **Aufschiebungsstatus:** Keine Aufschiebung
[22] **Anmeldetag:** 10.06.2024
[15] **Eintragungstag:** 12.11.2024
[----] **Veröffentlichungsdatum:** 06.12.2024
[54] **Erzeugnis(se):** Intelligente Projektoren [Smart Projectors]
[51] **Klasse(n):** 16-02
[----] **Klassenversion:** 14
[----] **Zahl der Darstellungen:** 6
[73] **Inhaber:** Grigorii Petrovich Grabovoi, Belgrad, RO
[72] **Entwerfer:** Grigorii Petrovich Grabovoi, Belgrad, RO
[----] **Bewirkte Schutzdauer:** 5 Jahre
[----] **Fälligkeit:** 30.06.2029
-

[-----] **Zahlungsfrist:** 31.12.2029

[-----] **Erstmalige Übernahme in DPMRegister:** 13.11.2024

[-----] **Tag der (letzten) Aktualisierung in DPMRegister:** 13.11.2024; 06.12.2024

Verfahrensdaten

Eintragung

[-----] **Verfahrensart:** Eintragung

[-----] **Verfahrensstand:** Das Design wurde eingetragen

[-----] **Verfahrensstandtag:** 12.11.2024

[-----] **Heftnummer:** 49

[-----] **Heftteil:** Teil 1a

[-----] **Heftjahr:** 2024

[45] **Veröffentlichungsdatum:** 06.12.2024

Design-Darstellungen

402024100406-0001.1



402024100406-0001.2



402024100406-0001.3



402024100406-0001.4



402024100406-0001.5



402024100406-0001.6



Fotokopije žigova

Dela, uređaji i delatnost koju obavlja G.P. Grabovoi su zaštićeni žigovima:

Evropske unije „GRABOVOI®” sa registarskim brojem № 009414673 od 18.02.2011. godine (datum podnošenja prijave 30.09.2010. godine) i Evropske unije „GRIGORI GRABOVOI®” sa registarskim brojem № 009414632 od 18.02.2011. godine (datum podnošenja prijave 30.09.2010. godine). Podaci o navedenim žigovima su dati na zvaničnom veb-sajtu Kancelarije za harmonizaciju unutrašnjeg tržišta Evropske unije koja registruje žigove <http://oami.europa.eu/ows/rw/pages/index.en.do>. Adresa: Avenida de Europa, 4E-03008 Alicante SPAIN, Telephone+3496 5139100; Email:information@oami.europa.eu





Australije „GRABOVOI®” sa registarskim brojem № 1477713 od 02.07.2012. godine (datum podnošenja prijave 01.03.2012. godine) i „GRIGORI GRABOVOI®” sa registarskim brojem № 1477714 od 02.07.2012. godine (datum podnošenja prijave 01.03.2012. godine). Podaci o navedenim žigovima su dati na zvaničnom veb-sajtu Zavoda za Intelektualnu svojinu Australije (Intellectual Property Australia): <http://www.ipaustralia.gov.au> Адрес: The Canberra Central Office, Ground Floor, Discovery House, 47 Bowes Street, Phillip ACT 2606; e-mail: assist@ipaustralia.gov.au



Australian Government

IP Australia

Discovery House Phillip ACT 2606
PO Box 200, Woden ACT 2606
Australia
Phone: 1300 651 010
International Callers: +61-2 6283 2999
Facsimile: +61-2 6283 7999
Email: assist@ipaustalia.gov.au
Website: www.ipaustalia.gov.au

21/03/2012

International Bureau, WIPO
34, chemin des Colombettes
P.O. Box 18
1211 Geneva 20,
SWITZERLAND

**MADRID AGREEMENT AND PROTOCOL
COMPLETION OF EX OFFICIO EXAMINATION
- INTERIM STATUS OF A MARK -
Rule 18BIS(1) (a) and (b)**

RE: International Registration No. 1106610 / Trade Mark No. 1477713
For the mark: (Words) GRABOVOI
Holder of the international registration:
Grigori Grabovoi

The above International Registration Designating Australia has been accepted for protection for the following goods/services:

Class: 9

Apparatus for recording, transmission or reproduction of sound or images; magnetic data carriers, recording discs; automatic vending machines and mechanisms for coin-operated apparatus; cash registers, calculating machines, data processing equipment and computers; fire-extinguishing apparatus; data-processing programs; recorded and unrecorded data carriers of all kinds, in particular CDs, MDs, DVDs, video tapes and audio cassettes

Class: 16

Paper, cardboard and goods made from these materials, not included in other classes; printed matter; bookbinding material; photographs; stationery; adhesives for stationery or household purposes; artists' materials; paint brushes; typewriters and office machines (except furniture); instructional and teaching material (except apparatus)

Class: 41

Holistic medical coaching, providing electronic publications (non-downloadable); presentation of live performances, academies (education), education and instruction, correspondence courses,



IPAAustralia • Patents • Trade Marks • Designs • Plant Breeder's Rights

ABN 38 113 072 755

arranging and conducting of cultural and sports events, providing of training; arranging and conducting of conferences, arranging and conducting of congresses, arranging and conducting of symposiums, coaching, vocational guidance, arranging and conducting of seminars, arranging and conducting of workshops (providing of training), arranging and conducting of colloquiums, arranging of exhibitions for cultural or educational purposes, entertainment; sporting and cultural activities; translation; conducting public readings and live performances (entertainment); services of a publishing firm, except printing; providing recreation facilities; providing games on the Internet; editing of texts (except publicity texts); film, video tape film, audio and television film production for all media; rental of film, video tape film, audio and television film productions on media of all kinds, editorial services, namely proof-reading of books and periodicals; correspondence courses

Class: 44

Medical services; holistic medical services in the fields of naturopathy and alternative medicine; acupuncture services, bioresonance therapy; psycho-mental services to influence and create emotional balance; mental healing; meditative and non-meditative physical and mental exercises being a guide to accessing self-healing powers for therapeutic purposes; healing counselling, medical and psycho-mental life counselling; consultancy with regard to holistic medical matters

If a Notification of Provisional Refusal has been issued in relation to this IRDA, the protection may not apply to all of the goods and/or services originally claimed.

Once a trade mark is accepted, it must be advertised in our Official Journal of Trade Marks. Your trade mark will be advertised on 22/03/2012.

Within 3 months after advertisement (the opposition period), other people may oppose protection of your trade mark. If no one has opposed the protection of your trade mark, or seeks an extension of time, by the end of the opposition period, your trade mark will be protected.

If notice of opposition is filed you will be notified, and in order to receive further documentation relating to the opposition, you will need to supply an address for service in Australia.

Registrar of Trade Marks
IP Australia

Japan „GRABOVOI®” sa registarskim brojem № 1106610 od 14.02.2013. godine (datum podnošenja prijave 01.03.2012. godine) i „GRIGORI GRABOVOI®” sa registarskim brojem № 1106611 od 14.02.2013. godine (datum podnošenja prijave 01.03.2012. godine). Podaci o navedenim žigovima su dati na zvaničnom veb-sajtu Digitalne biblioteke industrijske svojine zavoda za patente Japan http://www.ipdl.inpit.go.jp/homepg_e.ipdl Japan Patent Office Address: 3-4-3 Kasumigaseki, Chiyoda-ku, Tokyo 100-8915, Japan E-mail: PA1B00@jpo.go.jp

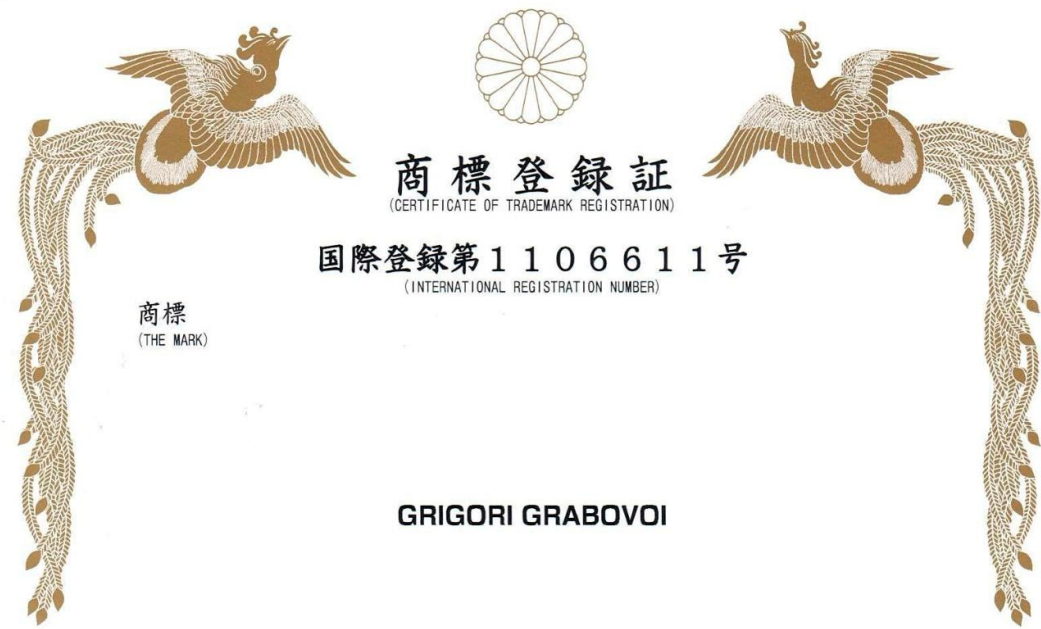

商標登録証
(CERTIFICATE OF TRADEMARK REGISTRATION)

国際登録第 1 1 0 6 6 1 1 号
(INTERNATIONAL REGISTRATION NUMBER)

商標
(THE MARK)

GRIGORI GRABOVOI

指定商品又は指定役務並びに商品及び役務の区分
(LIST OF GOODS AND SERVICES)

9 Apparatus for recording, transmission or reproduction of sound or images; magnetic data carriers, recording discs; automatic vending machines and mechanisms for coin-operated apparatus; cash registers, calculating

その他別紙記載 (REFER TO THE ATTACHED SHEET)

商標権者
(OWNER OF THE TRADEMARK RIGHT)

Grigori Grabovoi

Kanalstr. 43 22085 Hamburg
(Germany)

国際登録日
(INTERNATIONAL REGISTRATION DATE)

01.04.2011

登録日
(REGISTRATION DATE)

平成25年 4月 5日 (April 5, 2013)

この商標は、登録するものと確定し、商標原簿に登録されたことを証する。
(THIS IS TO CERTIFY THAT THE TRADEMARK IS REGISTERED ON THE REGISTER OF THE JAPAN PATENT OFFICE.)

平成25年 4月 5日 (April 5, 2013)

特許庁長官
(COMMISSIONER, JAPAN PATENT OFFICE)

深野弘行



商標登録証

(続葉 1)

(CERTIFICATE OF TRADEMARK REGISTRATION)

国際登録第1106611号 (INTERNATIONAL REGISTRATION NUMBER)

指定商品又は指定役務並びに商品及び役務の区分

(LIST OF GOODS AND SERVICES)

- (9) machines, data processing equipment and computers; fire-extinguishing apparatus; data-processing programs; recorded and unrecorded data carriers of all kinds, in particular CDs, MDs, DVDs, video tapes and audio cassettes.
- 16 Paper, boxes of paper, table cloths of paper, table napkins of paper, cardboard and cardboard articles; printed matter; bookbinding material; photographs; stationery; adhesives for stationery or household purposes; artists' materials; paint brushes; instructional and teaching material (except apparatus).
- 41 Holistic medical coaching, providing electronic publications (non-downloadable); presentation of live performances, academies (education), education and instruction, correspondence courses, arranging and conducting of cultural and sports events, providing of training; arranging and conducting of conferences, arranging and conducting of congresses, arranging and conducting of symposiums, professional training and coaching services; vocational guidance, arranging and conducting of seminars, arranging and conducting of workshops (providing of training), arranging and conducting of colloquiums, arranging of exhibitions for cultural or educational purposes, entertainment; sporting activities; organization of exhibitions for cultural or educational purposes; conducting public readings and live performances (entertainment); services of a publishing firm, except printing; providing recreation facilities; providing games on the Internet; editing of texts (except publicity texts); film, video tape film, audio and television film production for all media; editorial services, namely proof-reading of books and periodicals; correspondence courses.
- 44 Medical services; holistic medical services in the fields of naturopathy and alternative medicine; acupuncture services, psycho-mental services to influence and create emotional balance; mental healing; healing counselling, medical and psycho-mental life counselling; consultancy with regard to holistic medical matters.

[以下余白]

Kine (Narodne Republike Kine) „GRABOVOI®” sa registarskim brojem № G1106610 od 01.10.2012. godine (datum podnošenja prijave 01.03.2012. godine) i „GRIGORI GRABOVOI®” sa registarskim brojem № G1106611 od 01.10.2012. godine (datum podnošenja prijave 01.03.2012. godine). Podaci o navedenim žigovima su dati na zvaničnom veb-sajtu Državnog zavoda za intelektualnu svojinu Narodne Republike Kine (SIPO) <http://sbcx.saic.gov.cn/traide/> Poštanski broj: 100028 Postbox: No.100088 poštansko sanduče, 104 filijala, Peking, Kina E-mail adresa: chinatrademarkdatabase@gmail.com Adresa: Room 213, № 14 Shuguangxili, Chaoyang, Peking, Kina.

STATEMENT OF GRANT OF PROTECTION

Rule 18ter(1) of the Common Regulations

<p>I. Office sending the statement:</p> <p>Trademark Office State Administration for Industry and Commerce People's Republic of China</p> <p>Sanlihe Donglu 8, Xicheng District Beijing 100820, China Tel: 8610-88650662 Fax: 8610-68050285</p>
<p>II. Number of the international registration: 1106611</p> <p>This statement is related to the above international registration notified on <u>03/01/2012</u> by WIPO.</p>
<p>III. Name of the holder: GRIGORI GRABOVOI</p>
<p>IV. Protection is granted to the mark that is the subject of this international registration for all the goods and/or all the services requested.</p>
<p>V. Signature or official seal of the Office sending the statement:</p> <div style="text-align: center;">  </div>
<p>VI. Date on which the statement was sent: 10/01/2012</p>

STATEMENT OF GRANT OF PROTECTION

Rule 18ter(1) of the Common Regulations

I. Office sending the statement: Trademark Office State Administration for Industry and Commerce People's Republic of China	Sanlihe Donglu 8, Xicheng District Beijing 100820, China Tel: 8610-88650662 Fax: 8610-68050285
II. Number of the international registration: 1106610 This statement is related to the above international registration notified on <u>03/01/2012</u> by WIPO.	
III. Name of the holder: GRIGORI GRABOVOI	
IV. Protection is granted to the mark that is the subject of this international registration for all the goods and/or all the services requested.	
V. Signature or official seal of the Office sending the statement: 	
VI. Date on which the statement was sent: 10/01/2012	

Sjedinjenih Američkih Država „GRABOVOI®” sa registarskim brojem № 4329566 od 30.04.2013. godine (datum podnošenja prijave 02.03.2011. godine) i „GRIGORI GRABOVOI®” sa registarskim brojem № 85255853 od 19.07.2013. godine (datum podnošenja prijave 02.03.2011. godine). Podaci o navedenim žigovima su dati na zvaničnom veb-sajtu Kancelarije za patente i žigove SAD-a /United States Patent and Trademark Office koji registruje žigove <http://www.uspto.gov> Adresa: P.O. Box 1450, Alexandria, VA 22313-1450, Telephone [1-800-786-9199](tel:1-800-786-9199); Email: TrademarkAssistanceCenter@uspto.gov

United States of America
United States Patent and Trademark Office

Grabovoi

Reg. No. 4,329,566 GRABOVOI, GRIGORI PETROVICH (RUSSIAN FED. INDIVIDUAL)

Registered Apr. 30, 2013 MOSCOW, RUSSIAN FED.

Int. Cl.: 41

SERVICE MARK

SUPPLEMENTAL REGISTER

FOR: PROFESSIONAL COACHING SERVICES IN THE FIELD OF HOLISTIC MEDICINE, MENTAL AND SPIRITUAL TECHNOLOGIES; EDUCATION SERVICES, NAMELY, PROVIDING EDUCATIONAL WORKSHOPS AT ACADEMIES, AND PROVIDING CLASSES AND APPRENTICESHIPS, ALL IN THE FIELD OF HOLISTIC MEDICINE, MENTAL AND SPIRITUAL TECHNOLOGIES; EDUCATION IN THE FIELDS OF HOLISTIC MEDICINE, MENTAL AND SPIRITUAL TECHNOLOGIES RENDERED THROUGH CORRESPONDENCE COURSES; ORGANIZING ARRANGING AND CONDUCTING LECTURES, LIVE EDUCATION SEMINARS AND COACHING IN THE FIELD OF HOLISTIC MEDICINE, CONDUCTING WORKSHOPS AND SEMINARS IN THE FIELD OF HOLISTIC MEDICINE, MENTAL AND SPIRITUAL TECHNOLOGIES; PUBLISHING OF ELECTRONIC PUBLICATIONS, IN CLASS 41 (U.S. CLS. 100, 101 AND 107).

FIRST USE 7-1-2012, IN COMMERCE 7-1-2012.

THE MARK CONSISTS OF STANDARD CHARACTERS WITHOUT CLAIM TO ANY PARTICULAR FONT, STYLE, SIZE, OR COLOR.

THE NAME(S), PORTRAIT(S), AND/OR SIGNATURE(S) SHOWN IN THE MARK IDENTIFIES GRIGORI PETROVICH "GRABOVOI", WHOSE CONSENT(S) TO REGISTER IS MADE OF RECORD.

SER. NO. 85-255,787, FILED P.R. 3-2-2011; AM. S.R. 7-12-2012.

VERNA BETH RIRIE, EXAMINING ATTORNEY



Verna Beth Ririe
Acting Director of the United States Patent and Trademark Office

Sertifikat „Idivorski Laboratorija” o usaglašenosti uređaja PRK-1UM sa propisima elektromagnetske kompatibilnosti

Idivorski laboratorije d.o.o. Beograd
Volgina 15, 11060 Beograd
tel: +381 11 6776329
www.idvorsky.com
office@idvorsky.com
Sertifikaciono telo



SERTIFIKAT O PREGLEDU TIP A broj 00093 01518

prema **Pravilniku o elektromagnetskoj kompatibilnosti** (Sl. glasnik RS br. 25/2016 i 21/2020)

DATUM IZDAVANJA: 07.10.2024. VAŽI DO: 06.10.2027.

PODNOŠILAC ZAHTEVA: Preduzetnik Grigorii Grabovoi PR
KONSALTING TECHNOLOGIES OF ETERNAL DEVELOPMENT
Kneza Mihaila 21A lokal 113, 11102 Beograd

NAZIV / VRSTA APARATA: Uređaj za razvoj koncentracija večnog života PRK-1UM tri-mod

ROBNA MARKA: GRABOVOI ®
GRIGORII GRABOVOI ®

PROIZVOĐAČ: Preduzetnik Grigorii Grabovoi PR
KONSALTING TECHNOLOGIES OF ETERNAL DEVELOPMENT
Kneza Mihaila 21A lokal 113, 11102 Beograd

TIP / MODEL: **PRK-1UM tri-mod**



Opis aparata (proizvoda), namena i tehnički podaci:

Uređaj za razvoj koncentracija (**ne smatra se medicinskim uređajem**).

Tehnički podaci:

Nominalni napon: 5 V DC
Nominalna struja: 0,4 A
Dimenzije: 200 mm x 160 mm x 65 mm
Masa: 1 kg

Izveštaji sa ispitivanja

Primenjeni standardi:	Broj izveštaja:	Izdat od:	Datum:
SRPS EN IEC 55014-1:2021 SRPS EN IEC 55014-2:2021 SRPS EN IEC 61000-3-2:2019 + A1:2021 SRPS EN 61000-3-3:2014 + A1:2020 + A2:2021 + AC:2022	1446-1	Idivorski laboratorije	21.03.2024.

obrazac ILCB.TI02.04/02

EMC Sertifikat o pregledu tipa broj: 0009301518

strana 1 od 2

Ostala tehnička dokumentacija		Oznaka:	Datum:
1.	Deklaracija o usaglašenosti	37/24	07.10.2024.
2.	Instrukcije za uključivanje uređaja	Uputstvo za rukovanje_PRK-1UM PDF file modified on 02/10/2024 at 14:25:28	
3.	Tehnički podaci o komponentama	Tehnički podaci o komponentama_PRK-1UM PDF file modified on 02/10/2024 at 14:25:15	
4.	Spisak sastavnih delova	Spisak sastavnih delova_PRK-1UM PDF file modified on 02/10/2024 at 14:25:28	
5.	Electrical scheme of a modified device	Montazna sema_5v_PRK-1UM (.jpg file)	
6.	Sertifikat ISO 9001:2015	Intercert USA, IC-QM-2010073	16.10.2020.

Prilozi

- Nema.

Napomene:

Sertifikat važi samo za uređaj sa:

- postavljena 4 feritna jezgra unutra uređaja (pozicije prikazane u Izveštaju o EMC ispitivanju broj 1446-1): CF-65SN (2 komada, po 3 namotaja), CF-50R (2 komada, po 1 i 2 namotaja).
- jedno feritno jezgro CF-65SN (2 namotaja) postavljeno na USB DC kabl za napajanje dužine 95 cm, na oko 3 cm od USB konektora na uređaju
Proizvođač ferita: Crown Ferrite Enterprise Co., Taipei, Taiwan
- Eksterni AC/DC adapter ili Power bank nisu sastavni deo niti pribor koji se isporučuje uz ovaj uređaj i nisu predmet sertifikacije.

Pregledom tipa opreme, tj. pregledom tehničke dokumentacije dostavljene od strane podnosioca, izdaje se:

ZAKLJUČAK

Obimom pregleda obuhvaćeni su svi aspekti bitnih zahteva i relevantnih elektromagnetnih pojava. Aparat ZADOVOLJAVA SVE BITNE ZAHTEVE iz Priloga 1 Pravilnika o elektromagnetskoj kompatibilnosti (Službeni glasnik RS br. 25/2016 i 21/2020):

- elektromagnetske smetnje koje prouzrokuje oprema ne prelaze nivo iznad kog radio i telekomunikaciona oprema ili druga oprema ne može da radi kako je predviđeno;
- nivo imunosti opreme na elektromagnetske smetnje koje se očekuju pri upotrebi opreme su u skladu sa njenom predviđanom namenom, koji toj opremi omogućava da radi bez neprihvatljivog pogoršanja njenih radnih karakteristika za predviđenu namenu.

Uslovi važenja sertifikata:

- Sertifikat važi samo uz sve priloge.
- Zabranjeno je kopiranje i umnožavanje, osim u celosti.
- Sertifikat ne važi ukoliko su na proizvodu sprovedene izmene. Izmene se moraju prijaviti Idvorski laboratorijama radi provere usaglašenosti sa tipom i izdavanja dopune/izmene/novog sertifikata po potrebi.
- Proizvođač je odgovoran za usaglašenost prema svim propisima primenljivim na proizvod.
- Usaglašenost svakog komada opreme/aparata/proizvoda sa tipom je obaveza i odgovornost proizvođača koji preuzima mere interne kontrole proizvodnje.
- Podnosilac zahteva snosi odgovornost za autentičnost dostavljene tehničke dokumentacije i u obavezi je da istu i Sertifikat čuva 10 godina od dana proizvodnje poslednjeg uređaja.

Mesto izdavanja:

Beograd



Direktor:



Saša Jorgovanović, dipl.el.inž.

Dodatni izveštaj „Idvorski laboratorija” o ispitivanjima uređaja PRK-1UM sa laserom klase 1

IDVORSKY LABORATORIES Ltd. Belgrade
Volgina 15, 11060 Belgrade, Serbia

www.idvorsky.com
office@idvorsky.com
Phone: +381 11 6776329

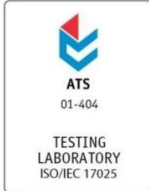

EMC TEST REPORT #	1446-3	 
Date of issue	18.07.2024.	
Date of testing	12. and 15.07.2024.	
Job #	1446	
Customer	Grigorii Grabovoi PR KONSALTING TECHNOLOGIES OF ETERNAL DEVELOPMENT, Kneza Mihaila 21A lok 113 TC Milenijum, 11102 Beograd, Srbija	
Manufacturer	Grigorii Grabovoi PR KONSALTING TECHNOLOGIES OF ETERNAL DEVELOPMENT, Kneza Mihaila 21A lok 113 TC Milenijum, 11102 Beograd, Srbija	
Product/EUT	The device of development of concentrations of eternal life PRK-1UM is of three-modes	
Model	PRK-1UM three-modes	
Serial No.	P189489D82.2M1	
VERDICT (based solely on tests listed in Clause 1)	PASS	
Remarks:	None.	

Tested by:

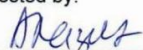
LAB engineer, Andrijana Lazić

LAB technician, Slaven Pavlekić

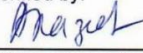

LAB apprentice Miloš Maksimović

Verified by:

LAB engineer, Andrijana Lazić

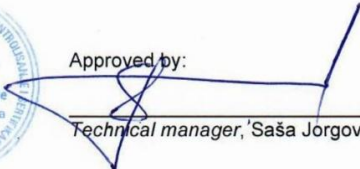

Approved by:

Technical manager, Saša Jorgovanović

Disclaimer:

This testing and results apply only for tested sample of the product (EUT). Laboratory is not responsible for the data submitted by the customer. Laboratory accepts no responsibility either misuses or wrong interpretations and decisions based on this report.

This report is not valid unless signed/authorized and shall not be reproduced except in full
EMC Test Report #1446-3

form IL.TR.EMC2/1
Page 1 of 19

1. TEST SUMMARY

The EUT is tested as tabletop equipment.

This is a **partial** test report.

The EUT was previously tested according to **EN IEC 61000-3-2:2019 + A1:2021, EN 61000-3-3:2013 + A1:2019 + A2:2021 + AC:2022-01, EN IEC 55014-1:2021 and EN IEC 55014-2:2021** and the test report #1446-2 was issued on 24.05.2024. by Idvorsky Laboratories.

The EUT was **partially** tested according to **EN IEC 55014-1:2021** in order to confirm compliance with the standard due to following changes:

- o New LED laser.

The EUT contains the following ports:

- enclosure port
- DC mains port – USB, 5 V DC.

Only tests concerning these ports shall be taken into account following the customer's request:

- enclosure port
- AC mains port of the auxiliary equipment.

Overview of the test results according to the test plan and specified performance criteria listed in Clause 3.5 and in EUT's mode of operation as noted in Clause 3.4 of this report:

STANDARD	TEST METHOD	PORT	MODE OF OPERATION	TEST SPECIFICATIONS	VERDICT
EN IEC 55014-1: 2021	Conducted RF emission test	AC mains port of the auxiliary equipment	The fourth and the fifth mode	Frequency range: 150 kHz – 30 MHz Measurement by application of LISN. Limits: Table 5, Clause 4.3.3.6 of EN IEC 55014-1: 2021	PASS
EN IEC 55014-1: 2021	Radiated RF emission test Applied ⁽¹⁾ EN 55016-2-3:2017 + A1:2019	Enclosure	The fourth and the fifth mode	Frequency range: 30 MHz – 1GHz ⁽²⁾ Limits: Table 9, Clause 4.3.4.5 of EN IEC 55014-1:2021 Performed in SAC with BiLog antenna at 3 m distance.	PASS

(1) In cases where, in regard to the year of publication, the test method referenced by the applied product standard does not coincide with the laboratory's scope of accreditation (SoA), the test method within the SoA shall be applied as noted. In all such cases, the test methods were compared and no significant differences consinging to the testing had been found.

(2) The highest internal frequency of the EUT is 16 MHz, according to the customer. The test was performed up to 1 GHz in accordance with clause 4.3.5.1 and table 10 of standard EN IEC 55014-1:2021.

2. CONTENTS

0. Front page
1. Test summary
2. Contents
3. Identification of the EUT
 - 3.1. Data
 - 3.2. Photographs/schematics
 - 3.3. Auxiliary equipment
 - 3.4. Modes of operation
 - 3.5. Performance criteria
 - 3.6. Product related notes
4. Testing location and conditions
5. Test results
 - 5.1. Conducted RF emission test
 - 5.2. Radiated RF emission test
6. Measurement equipment
7. Measurement uncertainty
8. General remarks
9. Appendixes

3. IDENTIFICATION of the EUT

3.1. Data*

EUT: PRK-1UM three-modes
Model: PRK-1UM three-modes
Serial number: P189489D82.2M1

Nominal voltage: 5 V DC
Nominal current: 0.4 A
Dimensions: 200 mm x 160 mm x 65 mm
Mass: 1 kg

USB power supply cable: 95 cm length, with the ferrite choke CF-65SN (2 turns) at 3 cm distance from EUT's connector

Note: EUT is not a medical device, according to the customer.

*Supplied by the customer

3.2. Photographs/schematics



EUT, top side



EUT, bottom side



EUT, front side



EUT, rear side



EUT, left side



EUT, right side



EUT, USB power supply cable (95 cm length)



The new laser label

3.3. Auxiliary equipment

MARK	NAME / TYPE / PURPOSE	QUANTITY
Turnmax power supply	AC/DC adapter for power supply of the EUT	1

Photographs:



AC/DC power supply adapter 5 V DC

3.4. Modes of operation

MODE OF OPERATION	DESCRIPTION
The fourth mode	The EUT is powered via USB cable of 95 cm connected to 5 V DC AC/DC adapter which is connected to 230 V, 50 Hz distribution network. Button 1 and 2 are off. The fourth mode is activated by turning on the button 3 which lights up blue when is turned on. This mode includes two lasers and an OLED screen. The inclusion of the laser can be observed from the back of the device through the ventilation holes. The required series of numbers is written to the SD card. An OLED display is used to read the numeric series. For this additional function, It is necessary to turn off the button on the left side of the OLED screen, insert the SD card and turn on the button on the left side of the OLED screen. Inscriptions appear on the display. SD card is inserted into a special slot on the front panel on the right side.
The fifth mode	The EUT is powered via USB cable of 95 cm connected to 5 V DC AC/DC adapter which is connected to 230 V, 50 Hz distribution network. Button 1 and 2 are off. Button 3 is turned on and lights up blue. This mode includes two lasers and an OLED screen. The inclusion of the laser can be observed from the back of the device through the ventilation holes. The required series of numbers is written to the SD card. An OLED display is used to read the numeric series. For this additional function, It is necessary to turn off the button on the left side of the OLED screen, insert the SD card and turn on the button on the left side of the OLED screen. Inscriptions appear on the display. SD card is inserted into a special slot on the front panel on the right side. The fifth mode is activated by pressing the metal button on the right side of the screen. The LED on the front panel above the SD card is flashing.

The manufacturer's remark: Mode 4th refers to the additional functions of modes 1 and 2.

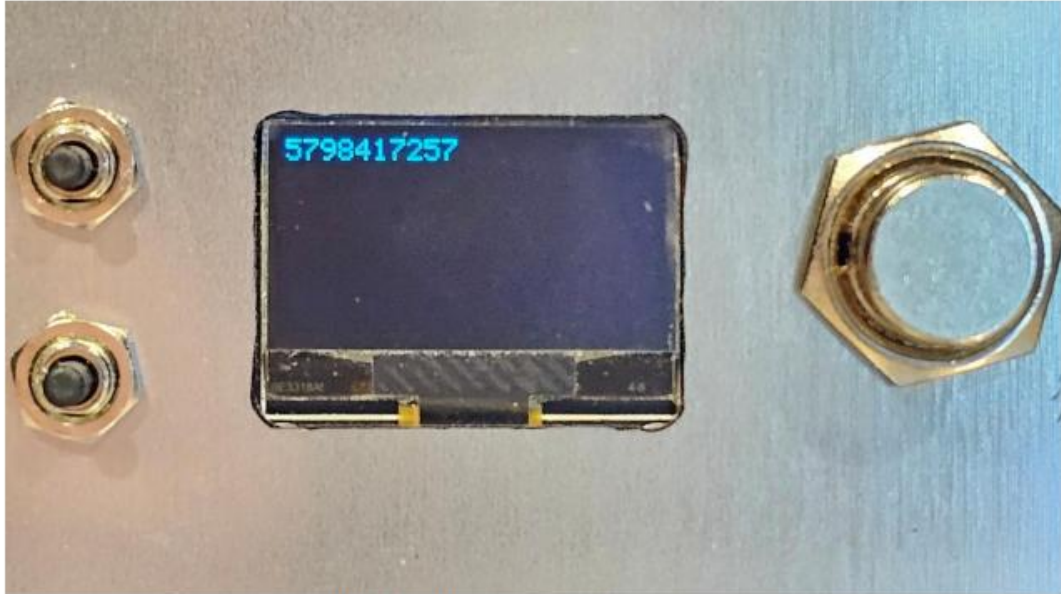

OLED display showing the numeric series

3.5. Performance criteria

3.5.1. Emission criteria

Conducted RF emission 150 kHz – 30 MHz: Required emission limits are according to the customer's request and also in accordance with table 5, Clause 4.3.3.6 of EN IEC 55014-1:2021.

Radiated RF emission 30 MHz – 1 GHz: Required emission limits are according to the customer's request and also in accordance with the limits from table 9, Clause 4.3.4.5 of EN IEC 55014-1:2021.

3.5.2. Immunity criteria

None.

3.6. Product related notes

Data of the new laser, provided by the customer:



Dot laser, red, 650 nm, 0.4 mW

LFD650-0.4-12(9x20)
 Order Number: 70108507

Main Parameters (*)	min	typ	max	Unit
Wavelength		650		nm
Optical Diode Power	0.2	0.4	0.4	mW
Operating Voltage	3	3	12	V DC
Operating Current	5	15	25	mA
Operating Temperature	-20		40	°C
Storage Temperature	-40		80	°C

Main Data

Warranty 1 years

Technical Parameters

Lifetime > 3,000 h
 RoHS yes

Optical Parameters

Beam Shape	Dot
Laser Class	1
Divergence	H - 1.0 mrad
Beam Diameter	3 mm
Size of Laserdot	<4.5mm@5m
Operating Distance	10 m
Optics	acryl lens
Laser technology	diode
Focus	collimated

Electrical Parameters

Power Supply LFNT-3

Mechanical Parameters

Size	Ø9x20 mm
Material	Brass
Cable length	100 mm
Wire type	28AWG, 0,14mm ²
Output Aperture	3 mm
Weight	6 g

(*) Over the complete operating temperature range

Features

- Compact size

- Laser Class 1
- Low power consumption
- Operating Voltage 3-12V DC
- Low cost

Picture



Cable color

Ground		black	GND
Positive		red	3 - 12, typ 3 V DC

Drawing

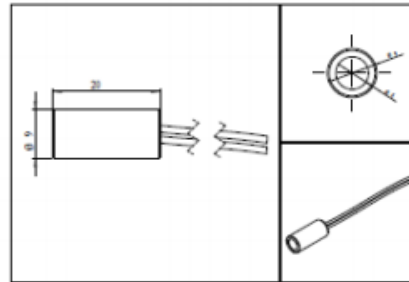

Safety Label



Valid Revision

13 | 06-MAY-2022

4. TESTING LOCATION AND CONDITIONS

Location: **Idvorsky Laboratories Ltd. Belgrade**
 Volgina 15, 11060 Belgrade, Serbia

Conditions:

Temperature: 25.7 °C – 27.3 °C
 Relative humidity: 50.1 % – 56.3 %
 Atmospheric pressure: 987 hPa – 989 hPa

5. TEST RESULTS

5.1. Conducted RF emission test

Date: 12.07.2024.
Test standard: EN IEC 55014-1:2021
Tested by: Andrijana Lazić, Slaven Pavlekić and Miloš Maksimović

5.1.1. Setup

5.1.1.1. The fourth mode

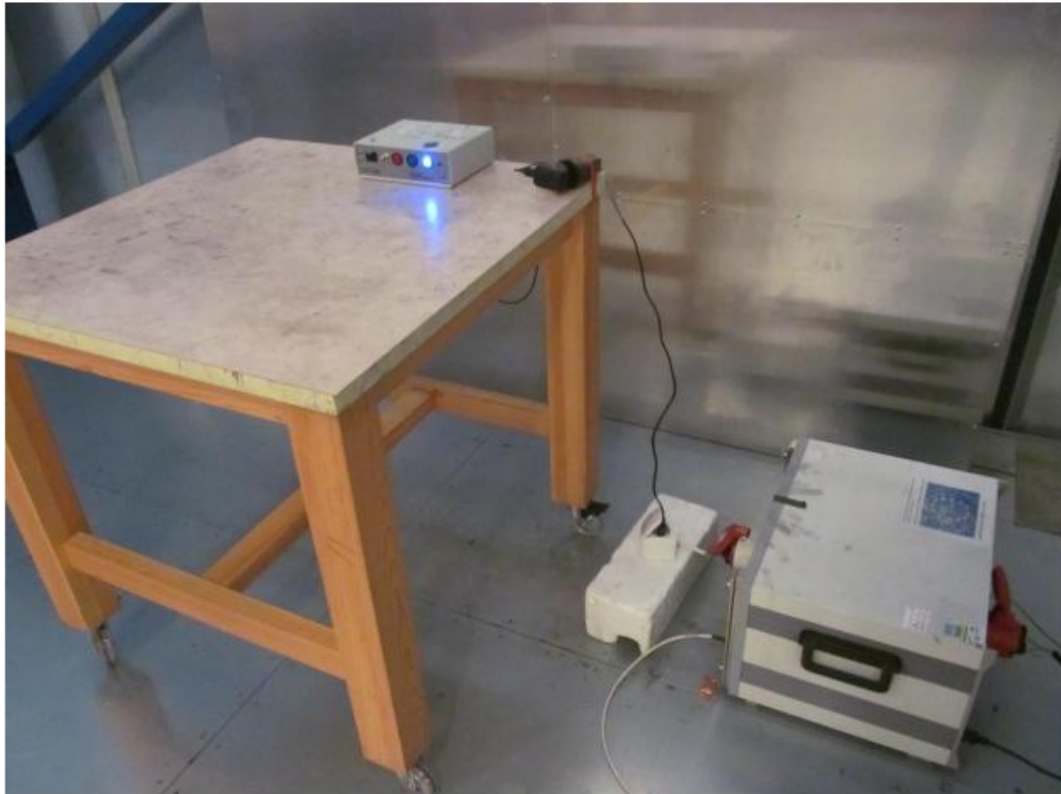

Port under test: AC mains port of the auxiliary equipment (LISN)
AC mains port voltage: 219 V, 50 Hz ($I_{max} = 10$ mA)
Frequency range: 150 kHz – 30 MHz
Pre-scan dwell time: 10 ms
Pre-scan detector: Peak
Step: 4 kHz
Final measurement time: 15 s
Mode of operation: The fourth mode

5.1.1.2. The fifth mode

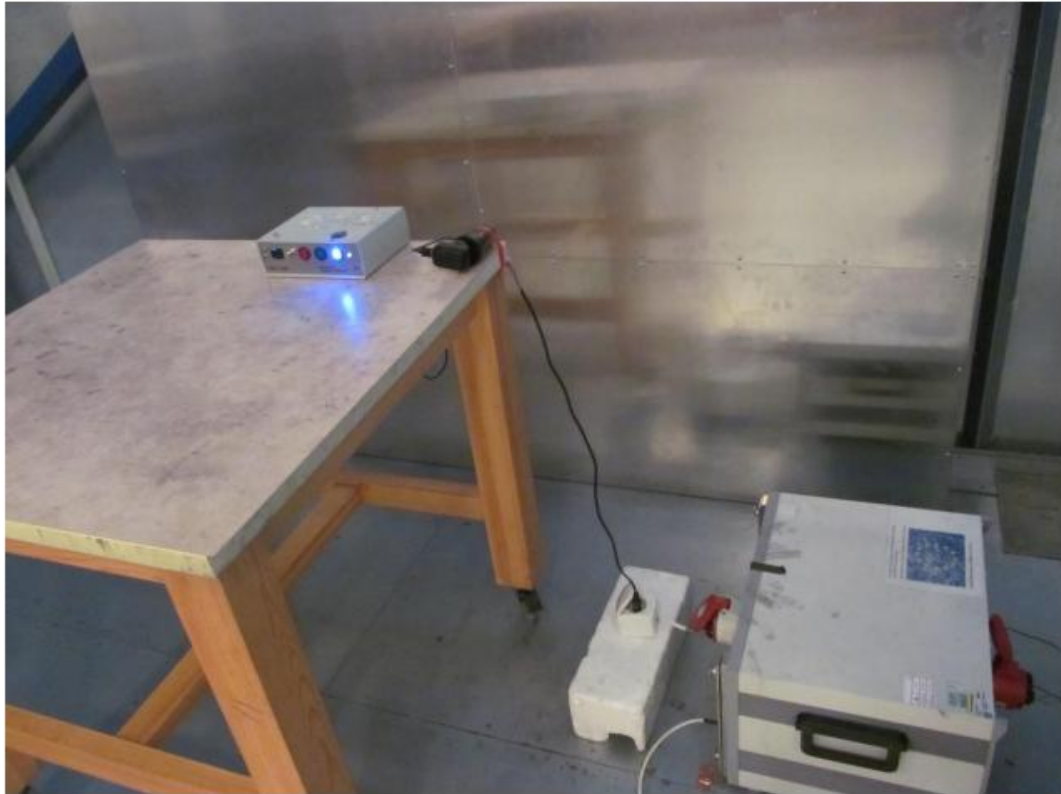

Port under test:	AC mains port of the auxiliary equipment (LISN)
AC mains port voltage:	219 V, 50 Hz ($I_{max} = 10 \text{ mA}$)
Frequency range:	150 kHz – 30 MHz
Pre-scan dwell time:	10 ms
Pre-scan detector:	Peak
Step:	4 kHz
Final measurement time:	15 s
Mode of operation:	The fifth mode

5.1.2. Results

5.1.2.1. The fourth mode

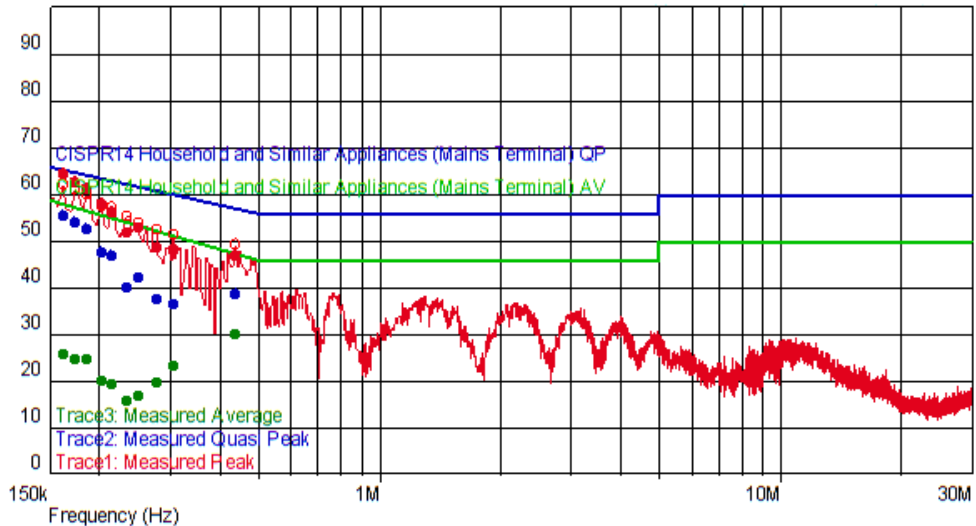

List of selected disturbances:

f [MHz]	Pk level [dBuV]	QP level [dBuV]	QP limit [dBuV]	QP margin [dB]	Av level [dBuV]	Av limit [dBuV]	Av margin [dB]	LINE
0.162	64.096	55.270	65.361	-10.090	25.856	58.169	-32.313	N
0.174	62.285	54.010	64.767	-10.760	24.905	57.397	-32.492	N
0.186	60.908	52.470	64.213	-11.750	24.618	56.677	-32.059	N
0.202	57.927	47.370	63.528	-16.160	20.227	55.786	-35.559	N
0.214	56.196	46.950	63.049	-16.100	19.436	55.163	-35.727	N
0.234	51.737	40.190	62.307	-22.120	15.987	54.198	-38.212	N
0.250	52.867	42.100	61.757	-19.660	16.777	53.484	-36.707	N
0.278	48.657	37.540	60.875	-23.340	19.607	52.338	-32.731	N
0.306	48.214	36.470	60.078	-23.600	23.474	51.302	-27.828	N
0.438	46.873	38.650	57.100	-18.450	30.193	47.429	-17.236	N

Limits: Clause 4.3.3.6, table 5 of EN IEC 55014-1:2021.

Verdict: **PASS**

5.1.2.2. The fifth mode

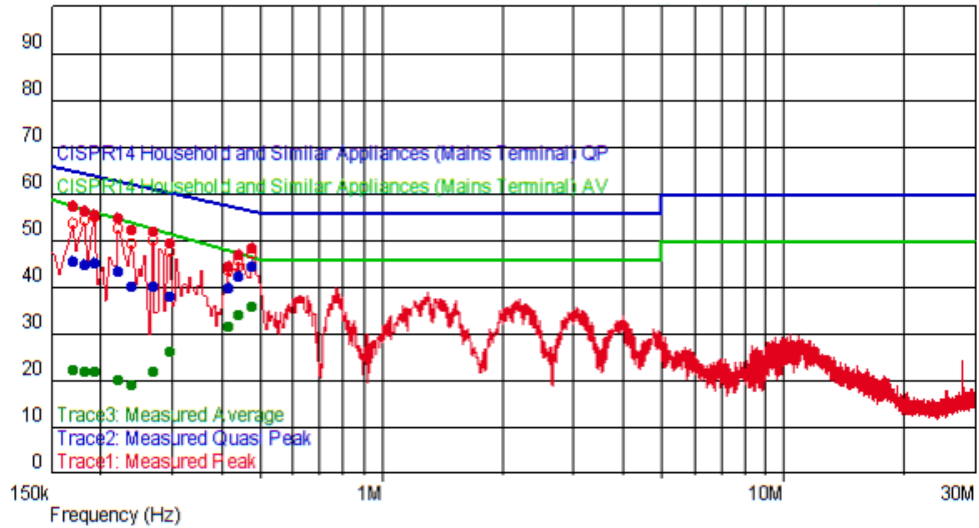

List of selected disturbances:

f [MHz]	Pk level [dBuV]	QP level [dBuV]	QP limit [dBuV]	QP margin [dB]	Av level [dBuV]	Av limit [dBuV]	Av margin [dB]	LINE
0.170	57.041	45.490	64.960	-19.470	22.301	57.649	-35.348	L1
0.182	56.218	44.800	64.394	-19.600	21.938	56.912	-34.975	L1
0.194	55.485	44.910	63.864	-18.950	21.975	56.223	-34.248	L1
0.222	54.694	43.120	62.744	-19.620	20.174	54.767	-34.593	L1
0.238	52.028	40.210	62.166	-21.960	19.158	54.015	-34.858	L1
0.270	51.751	40.180	61.118	-20.940	21.891	52.653	-30.762	L1
0.298	49.208	37.940	60.298	-22.360	26.118	51.588	-25.469	L1
0.418	44.385	39.690	57.488	-17.800	31.665	47.934	-16.269	L1
0.442	46.943	42.230	57.024	-14.790	33.963	47.331	-13.368	L1
0.478	48.369	44.180	56.374	-12.190	35.769	46.486	-10.717	L1

Limits: Clause 4.3.3.6, table 5 of EN IEC 55014-1:2021.

Verdict: **PASS**

5.1.3. Deviations

None.

5.1.4. Comments

None.

5.2. Radiated RF emission test

Date: 12. and 15.07.2024.
Test standard: EN 55016-2-3:2017 + A1:2019
Tested by: Andrijana Lazić, Slaven Pavlekić and Miloš Maksimović

5.2.1. Setup

Note: Pre-scan measurements were made in different modes of operation of the EUT in order to determine the worst case regarding radiated RF emission.

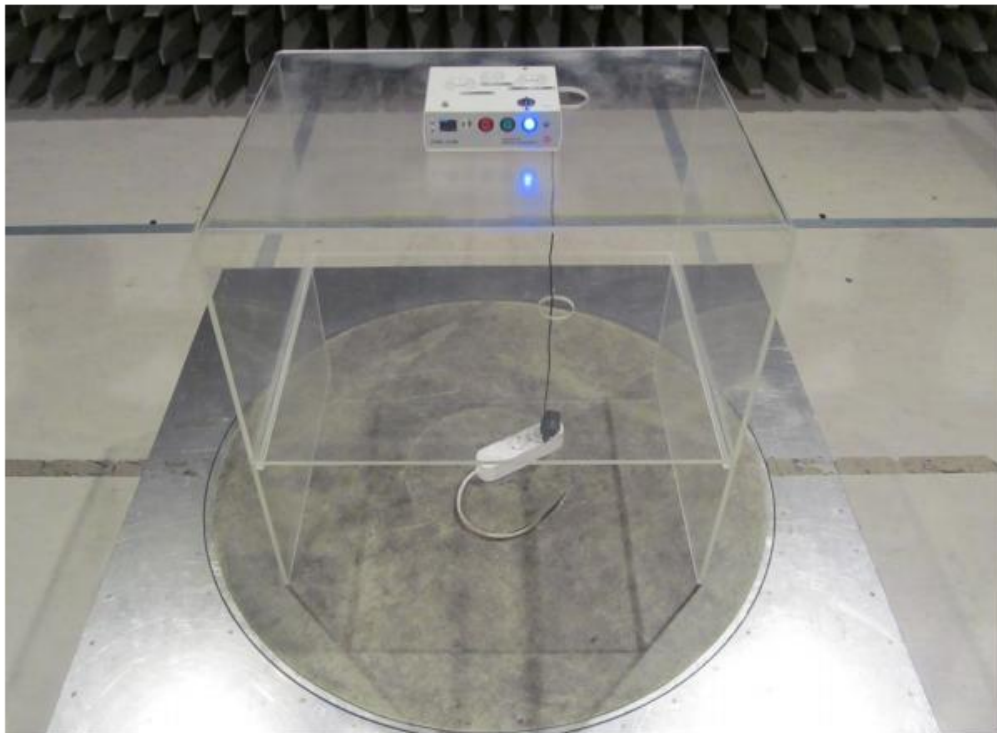

Test location:	semi-anechoic chamber
EUT to antenna distance:	3 m
Pre-scan RBW:	120 kHz (step 40 kHz)
Pre-scan dwell time:	2 ms
Final measurement:	15 s
Final RBW:	120 kHz
Mode of operation:	The fourth mode ($U = 223 \text{ V}$, $I_{\text{max}} = 10 \text{ mA}$)

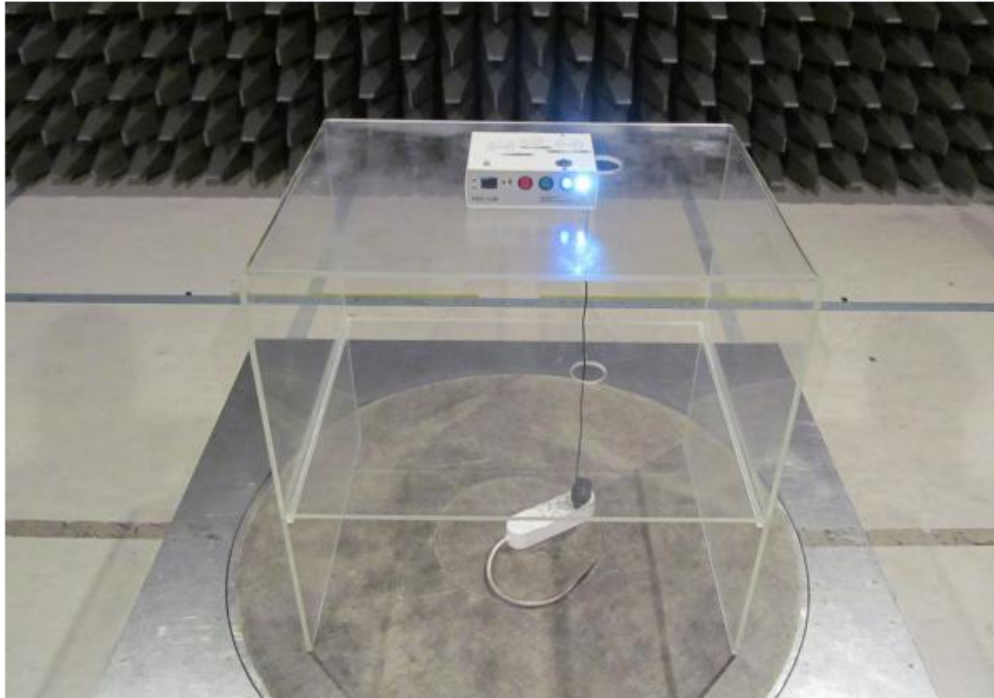

Test location: semi-anechoic chamber
 EUT to antenna distance: 3 m
 Pre-scan RBW: 120 kHz (step 40 kHz)
 Pre-scan dwell time: 2 ms
 Final measurement: 15 s
 Final RBW: 120 kHz
 Mode of operation: The fifth mode ($U = 223 \text{ V}$, $I_{\text{max}} = 10 \text{ mA}$)

Pre-scan, both modes of operation, deciding the worst case:

Pre-scan angles: 0° , 90° , 180° and 270°
 Pre-scan antenna height: 1 m
 Pre-scan antenna polarization: HOR and VER

Pre-scan, the worst case, complete test

Pre-scan angles: 0° , 90° , 180° and 270°
 Pre-scan antenna height: 1 m, 2.5 m and 4 m
 Pre-scan antenna polarization: HOR and VER
 Mode of operation: The fifth mode ($U = 223 \text{ V}$, $I_{\text{max}} = 10 \text{ mA}$)

Limits:

Frequency range [MHz]	Average limit dB($\mu\text{V}/\text{m}$)	Quasi-peak limit dB($\mu\text{V}/\text{m}$)	Peak limit dB($\mu\text{V}/\text{m}$)
30 – 230	--	40	--
230 – 1000	--	47	--

5.2.2. Results

5.2.2.1. Pre-scan, both modes of operation, deciding the worst case

The fourth mode

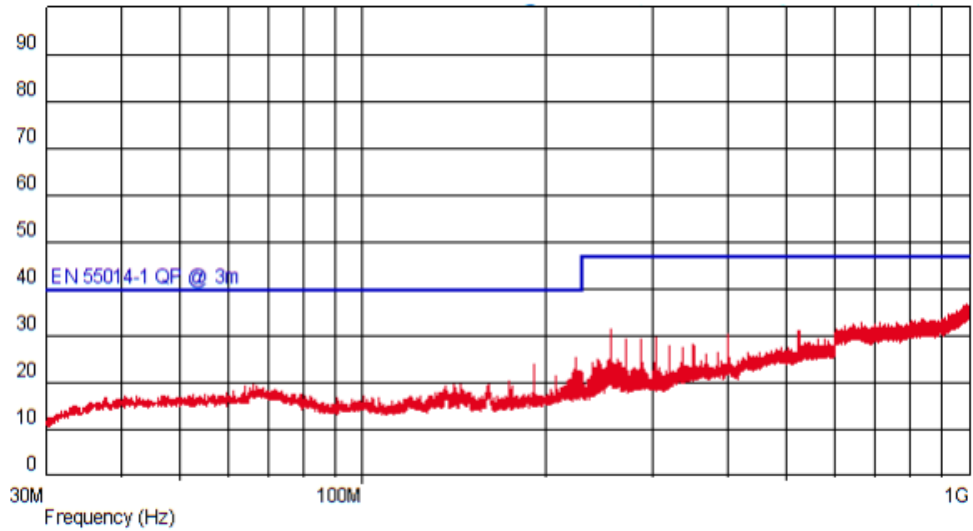

Note: Pre-scan measurement was made in order to determine the worst case regarding radiated RF emission.

The fifth mode

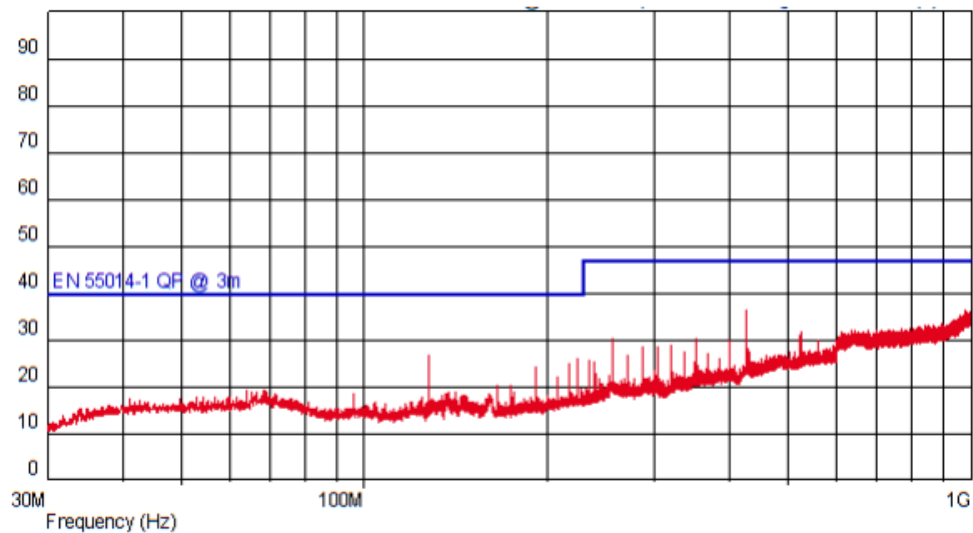

Note: Pre-scan measurement was made in order to determine the worst case regarding radiated RF emission.

5.2.2.2. Complete test, the fifth mode

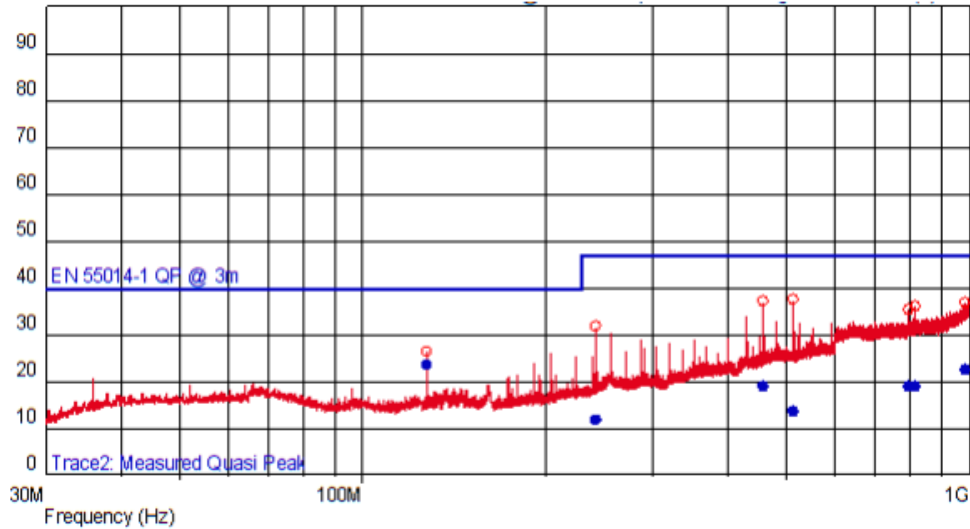

List of selected disturbances:

Frequency [MHz]	QP level [dBuV/m]	QP limit [dBuV/m]	Margin [dB]	Antenna polarization	Azimuth [deg]	Antenna height [m]
127.999	23.770	40	-16.230		85	1.030
241.960	12.010	47	-34.990	--	165	1.030
457.200	18.900	47	-28.100		2	1.820
513.601	13.520	47	-33.480	--	239	4.000
794.639	18.870	47	-28.130	--	360	3.990
814.520	19.190	47	-27.810		252	1.250
984.199	22.720	47	-24.280		66	1.250

Limits: Clause 4.3.4.5, table 9 of EN IEC 55014-1:2021

Verdict: **PASS**

5.2.3. Deviations

None.

5.2.4. Comments

The highest internal frequency of the EUT is 16 MHz, according to the customer. The test was performed up to 1 GHz in accordance with clause 4.3.5.1 and table 10 of standard EN IEC 55014-1:2021.

6. MEASUREMENT EQUIPMENT

The following equipment is used for tests:

Type	Manufacturer	Model	Ser.No.	IN number	USED IN TEST-S Reported in the Clause/s:
EMI receiver	Schaffner	SMR4503	81	0138	5.1. 5.2
Software	Teseq	Compliance 5 E/I v5.26.4	517-2881623-74 and 517-2846725-70	0125	5.1. 5.2
V-network 4-line	Teseq	NNB52	27384	0134	5.1
Antenna	Teseq	CBL6144	35349	0115	5.2
Semi anechoic chamber	Comtest	3m	/	0305	5.2
Antenna mast	Maturo	CAM-4.0	/	306	5.2
Controller	Maturo	MSU	/	307	5.2
Pulse limiter	Schwarzbeck	VTSD 9561-F	9561-F-N 0971	0356	5.1

7. MEASUREMENT UNCERTAINTY

For test 5.1: AC mains port: $U_{LAB} = U_{CISPR} = 3.4$ dB in frequency range 150 kHz – 30 MHz.
Expanded uncertainty of measurement, expressed as the standard uncertainty of measurement multiplied by the coverage factor $k = 2$, which for normal distribution corresponds to a coverage probability of approximately 95 %. Measurement uncertainty calculation is carried out according to EN 55016-4-2:2011 + A1:2014 + A2:2018.

For test 5.2: 4.9 dB (HOR 30 MHz – 300 MHz)
5 dB (VER 30 MHz – 300 MHz)
5.2 dB (HOR and VER 300 MHz – 1000 MHz)
Expanded uncertainty of measurement expressed as the standard uncertainty of measurement multiplied by the coverage factor $k = 2$, which for normal distribution corresponds to a coverage probability of approximately 95 %.
Measurement uncertainty is according to EN 55016-4-2:2011 + A1:2014 + A2:2018 ($U_{LAB} \leq U_{CISPR}$).

8. GENERAL REMARKS

Date format is dd.mm.yyyy.

Decimal mark is indicated by dot (.) within the report.

9. APPENDIXES

None.

END OF THE REPORT

